

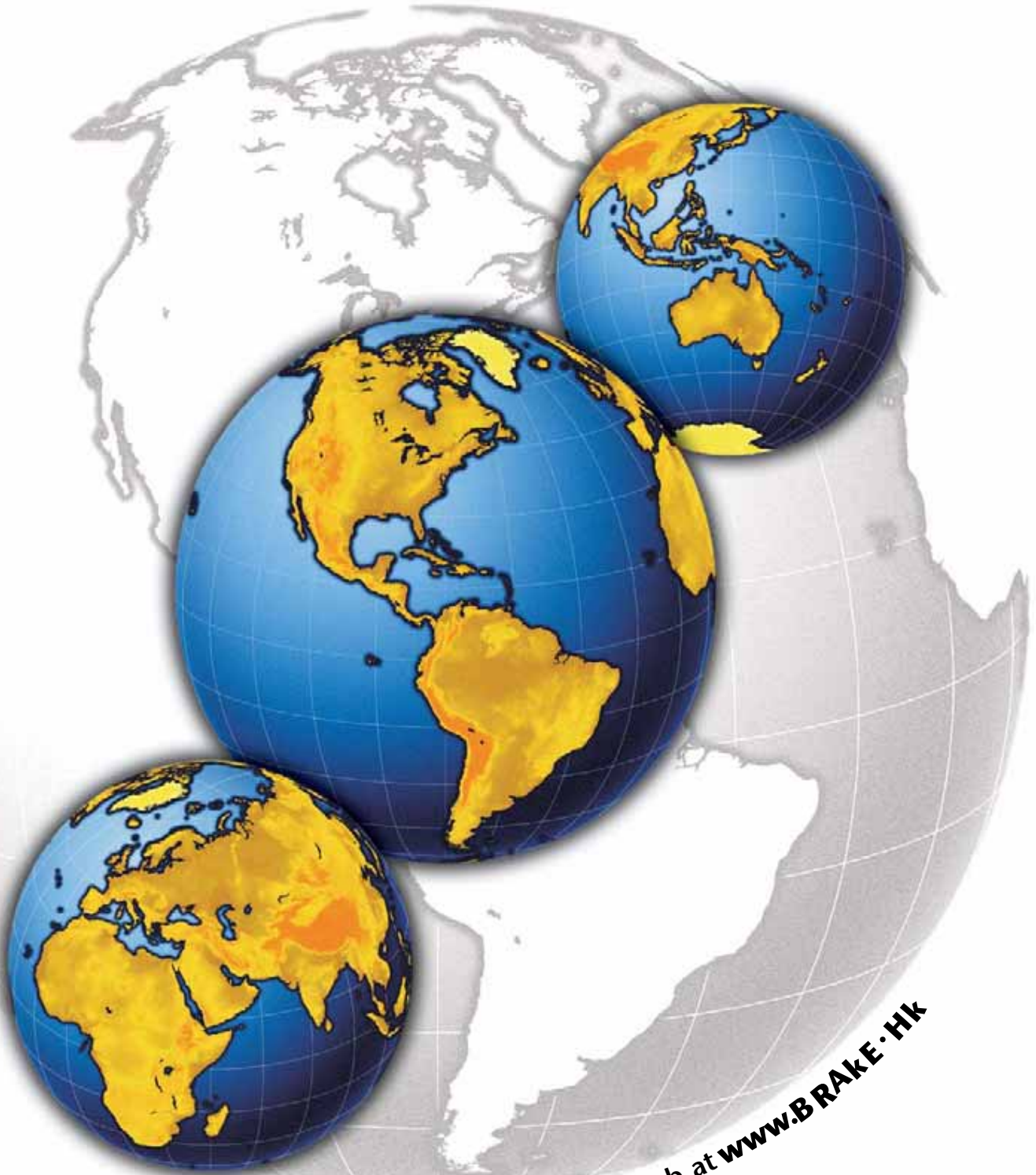

HeNan Modern Industrial Co., Limited

Professional Supplier and Manufacturer For Fluid coupling, gear coupling, Industry Brake.



Visit us on the web at www.BRAKE·HK



一流产品 一流服务

First-class products First-class service



HENAN MODERN INDUSTRIAL, CO LIMITED

ADD: NO.8 Linke ROAD, ZHENGZHOU, HENAN PROVINCE. CHINA Postcode: 450000

TEL: + 86-371-88881695 FAX: + 86-371-88881697 WEB: WWW.BRAKE.HK

About HMIC

HENAN MODERN INDUSTRIAL CO., LIMITED - HMIC™ is a Professional company that engaged in Industrial Parts manufacturing and Supply, Such as: Electro hydraulic brake, Electro hydraulic thruster, Emergency brake. Electro hydraulic power station, Motorized drum pulleys, Idlers, conveyor belt, Gear pump. Coupling, fluid coupling, gear reducer, crane load sensor, electronic industry scales, crane anemometer, crane alarm system, remote control system and so on.

Our factory covers an area of 3,30 00 Square Meters with advanced warehouse and leading manufacturing machines such as CNC lathe, CNC processing center, Full automatically painting line, full automatically cutting machine, Brake torque testing bed, motor testing system or etc.

During the past years, we have been dedicated to improving efficiency and performance of businesses in all types of industries above. Currently we have established long and reliable business relationship with hundreds key partners over 20 countries. Such as: Singapore, Vietnam, Philippines, Indonesia, India, Italy, Finland, Romania, Colombia, France, Australia, turkey, Brazil, and so on.

HMIC Serving a broad range of customers, including manufacturing and process industries, shipyards, ports, cement Plant, mining Industry, Steel mill, power plant, Oil industry, building machine. Wind turbine energy or etc

Professional and responsible running through the whole process of products manufacturing to make sure meet with the requirement of every client. Quick response, High quality products, competitive price, excellent after service, HMIC is committed to providing you with high quality equipment and service that increase the value and effectiveness of your business all the time. When you choose us, you already cooperation with trustworthy and reliability, and HMIC™ will surely increase your productivity and Business.

HMIC- CREATE VALUE FOR YOU ALL THE TIME!

HENAN MODERN INDUSTRIAL CO., LIMITED

Office TEL : + 86-371-8888-1695

+ 86-371-8888-1697

Office Fax : + 86-371-8752-3083

Website : www.brake.hk www.brakes.com.cn

Skype : winever1985

MSN : Cnbrake@hotmail.com

Yahoo : chengliya@yahoo.com

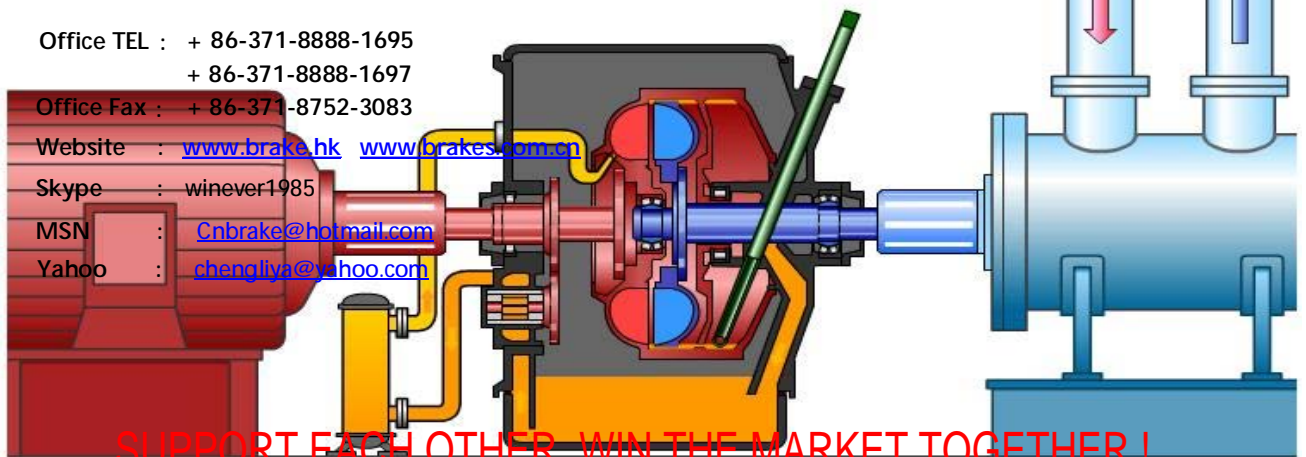

SUPPORT EACH OTHER, WIN THE MARKET TOGETHER!

一流产品 一流服务

First-class products First-class service



HENAN MODERN INDUSTRIAL, CO LIMITED

ADD: NO.8 Linke ROAD, ZHENGZHOU, HENAN PROVINCE. CHINA Postcode: 450000

TEL: + 86-371-88881695 FAX: + 86-371-88881697 WEB: WWW.BRAKE.HK

限矩型液力耦合器在不同使用场合下的结构形式：
Assembly type for different applications:

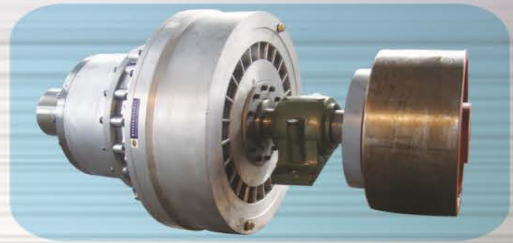



一流产品 一流服务

First-class products First-class service



HENAN MODERN INDUSTRIAL, CO LIMITED

ADD: NO.8 Linke ROAD, ZHENGZHOU, HENAN PROVINCE. CHINA Postcode: 450000

TEL: + 86-371-88881695 FAX: + 86-371-88881697 WEB: WWW.BRAKE.HK

调速型液力偶合器在不同使用场合下的结构形式：

Structural form of variable speed fluid coupling under different occasions:



联轴器在不同使用场合下的结构形式：

Structural form of coupling under different occasions:

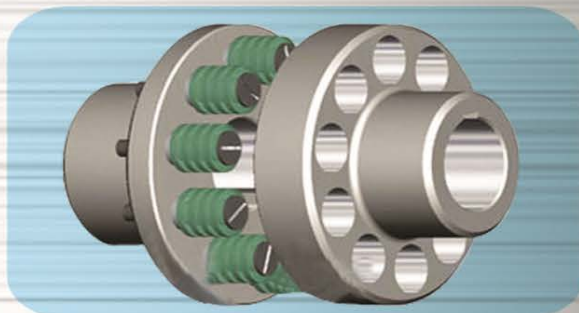
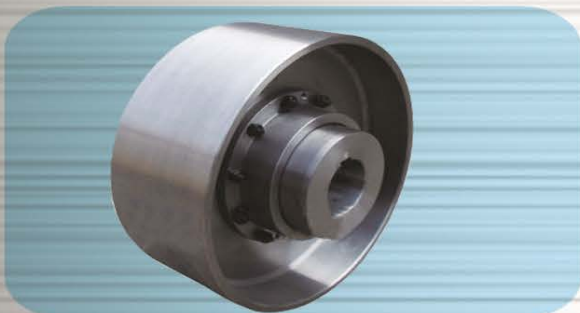



一流产品 一流服务
First-class products First-class service



HENAN MODERN INDUSTRIAL, CO LIMITED

ADD: NO.8 Linke ROAD, ZHENGZHOU, HENAN PROVINCE, CHINA Postcode: 450000
TEL: + 86-371-88881695 FAX: + 86-371-88881697 WEB: WWW.BRAKE.HK

产品特点

一、使用特点

1. 保护电动机，提高电机启动能力。
2. 缩短电动机启动时间，改善起动性能，减少起动平均电流。
3. 减少起动的冲击和振动，具有过载保护作用。
4. 在多机驱动系统中能均衡各电机的负荷。
5. 结构简单，运行可靠，无机械磨损，使用寿命长。

二、用途

胶带输送机、刮板输送机、链式输送机、螺旋输送机、挖掘机、斗轮挖掘机、各种提升机、球磨机、破碎机、磨煤机、塔式起重机、门式起重机、桥式起重机、斗轮堆取料机、离心机、洗砂机、制革转鼓、游艺机、搅拌机、拉丝机、炼胶机、注塑机、挤出机、预加水成球机、锅炉碎渣机等。

Characteristics of product

1. Characteristics of use:

- 1) Protect electric motor, improve the starting capability of electric motor.
- 2) Decrease the starting time of electric motor, improve starting functions, and decrease starting average electric current.
- 3) Decrease the strike and vibration of start, it has the function of protection against over-load.
- 4) In a multi-motor drive system, it can balance the loads of each electric motor.
- 5) with simple structure, reliable operation, without mechanical wear and has long operation life.

2. Applications

Belt conveyor. AFC conveyor. Chain conveyor. Screw conveyor. Excavators. Bucker wheel. Excavator. Bucket conveyor. Grinding mill. Crusher Coal planer. Tower crane. Gantry crane. Bridge crane. Blender equipment, Centrifuger. Washer. Leather-making machine. machine for recreation park mixer wire drawing machine. Extruder, dregs crusher of boiler. roller of leather making machine. plastic feeder. Rubber smelting machine. etc.

YOX系列限矩型液力偶合器规格选用表及功率图谱

The selection form of YOX series constant filling hydraulic power coupler specifications and power spectrum drawing

传动功率 Power trans (KW)	输入转速 Input speed (r/min)	500	600	750	1000	1500	3000
150					0.05-0.2	0.2-0.55	
180					0.1-0.3	0.5-1.1	
200					0.2-0.55	0.8-2.2	
220					0.4-1.1	1.5-3	12-16.5
250					0.8-1.5	2.5-5.5	15-30
280					1.5-3	4.5-8	25-50
320				1.1-2.2	2.5-5.5	9-18.5	45-73
340				1.6-3.1	3-9	12-22	
360				2-3.8	5-10	16-30	50-100
400				4-8	8-18.5	28-48	80-145
450				7-14	15-30	50-90	100-200
500				11-22	25-50	68-144	
560				18-36	40-80	120-270	
600				25-50	60-115	200-360	
650				37-73	90-176	260-480	
750			36-75	70-143	170-330	380-760	
875				145-280	330-620		
1000	83-165	160-300	260-590				
1150	175-350	265-615	525-1190				
1250	235-540	400-935	800-1800				
1320	315-710	650-1200	1050-2360				

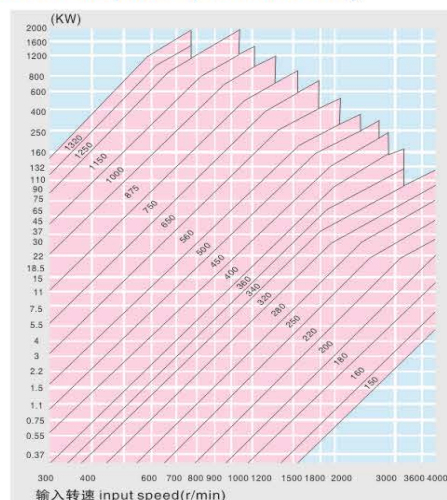

注：1、用户订货时请提供电机及工作机（或减速机）的轴的直径大小、长度键宽和键深尺寸。若选用带皮带轮式、带制动轮式或其它结构，还需提供有关详细技术参数，可按用户的特殊要求进行非标准设计生产。

2、当L1、L2超过表列L1max、L2max时可相应增加A。

Remarks: 1. when customers order goods, please provide the diameter, Length, key width and key depth sizes of electric motor and working machine (or deceleration machine). if you select type with belt wheel, with brake wheel or other structures, it is also needed to provide related technological parameters in detail. We may make non-standard design and production according to the special requirement of customers.
2. when L1 and L2 are greater than listed L1max and L2max, A should be increased correspondingly.



一流产品 一流服务
First-class products First-class service



HENAN MODERN INDUSTRIAL, CO LIMITED

ADD: NO.8 Linke ROAD, ZHENGZHOU, HENAN PROVINCE. CHINA Postcode: 450000

TEL: + 86-371-88881695 FAX: + 86-371-88881697 WEB: WWW.BRAKE.HK

YOX型结构图及主要技术参数：(YOX II、TVA同结构型)

YOX Type Structural Drawing and Main Technical Date:(YOX II、TVA the same structure type)



传动形式一：

YOX标准型由泵轮、外壳、后辅腔、主动节、从动节、弹性块作为主动部分，其中弹性块是柔性元件补偿安装不同心量，涡轮及涡轮轴组成从动部分，一般延长工作机时间为10-22秒。

Transmission form I :

Note:Standard model YOX takes outer wheel,shell,deley chamber, driring connection,dtiren connelction and elastic block as its driving parts,of which,the elastic block is a soft part with compensated installation and decentraction, Turbine and Turbine shaft make up slave part, normally prolong the time of working machine for 10-22 seconds.

规格型号 Specification Type	输入转速 Input speed (r/min)	传递功率 范围 Range of power transmitted (kw)	过载系数(Tg) Over load coeff		效率 Effic iency η	外型尺寸 Dimensions		最大输入孔 径及长度 Max.Input bore diameter &length (d1/L1)	最大输出孔 径及长度 Max.output bore diameter &length (d2/L2)	充油量 (L) Volume of filling oil		重量 Weight (KG)
			起动 start	制动 brake		D	A			40% qmin	80% qmax	
YOX150	1000	0.05-0.2	2-2.7	2-2.7	0.97	ϕ 195	175	ϕ 25/40	ϕ 20/40	0.2	0.42	6
	1500	0.2-0.55										
YOX180	1000	0.1-0.3	2-2.7	2-2.7	0.97	ϕ 232	207	ϕ 30/50	ϕ 25/50	0.24	0.48	7
	1500	0.5-1.1										
YOX200	1000	0.2-0.55	2-2.7	2-2.7	0.97	ϕ 254	194	ϕ 35/60	ϕ 30/60	0.6	1.2	8.8
	1500	0.8-2.2										
YOX220	1000	0.4-1.1	2-2.7	2-2.7	0.97	ϕ 278	225	ϕ 40/80	ϕ 35/80	0.76	1.52	13
	1500	1.5-3										
YOX250	1000	0.8-1.5	2-2.7	2-2.7	0.97	ϕ 305	240	ϕ 45/80	ϕ 40/80	1.1	2.1	16
	1500	2.5-5.5										
YOX280	1000	1.5-3	2-2.7	2-2.7	0.97	ϕ 345	252	ϕ 50/80	ϕ 45/110	1.4	2.8	21
	1500	4.5-8										
YOX320	1000	2.5-5.5	2-2.7	2-2.7	0.96	ϕ 380	278	ϕ 55/110	ϕ 45/110	2.2	4.4	28
	1500	9-18.5										
YOX340	1000	3-9	2-2.7	2-2.7	0.96	ϕ 390	298	ϕ 55/110	ϕ 50/110	2.7	5.3	36
	1500	12-22										
YOX360	1000	5-10	1.5-1.8	2-2.7	0.96	ϕ 415	310	ϕ 60/110	ϕ 55/110	3.4	6.7	42
	1500	16-30										
YOX400	1000	8-18.5	1.5-1.8	2-2.7	0.96	ϕ 465	355	ϕ 70/140	ϕ 65/140	5.2	10.4	65
	1500	28-48										
YOX450	1000	15-30	1.5-1.8	2-2.5	0.96	ϕ 520	384	ϕ 75/140	ϕ 70/140	7.5	15	79
	1500	50-90										
YOX500	1000	25-50	1.5-1.8	2-2.5	0.96	ϕ 582	435	ϕ 96/170	ϕ 90/170	10.3	20.5	105
	1500	68-144										
YOX560	1000	40-80	1.5-1.8	2-2.5	0.96	ϕ 634	490	ϕ 100/210	ϕ 100/210	13.2	26.4	152
	1500	120-270										
YOX600	1000	60-115	1.5-1.8	2-2.5	0.96	ϕ 695	510	ϕ 100/210	ϕ 115/210	16.8	33.6	185
	1500	200-360										
YOX650	1000	90-176	1.5-1.8	2-2.5	0.96	ϕ 760	556	ϕ 120/210	ϕ 130/210	24	48	230
	1500	260-480										
YOX750	1000	170-330	1.5-1.8	2-2.5	0.96	ϕ 860	578	ϕ 130/210	ϕ 140/210	34	68	350
	1500	380-760										
YOX875	750	145-280	1.5-1.8	2-2.5	0.96	ϕ 992	705	ϕ 150/250	ϕ 150/250	56	112	495
	1000	330-620										
YOX1000	600	160-300	1.5-1.8	2-2.5	0.96	ϕ 1138	735	ϕ 150/250	ϕ 160/280	74	148	650
	750	260-590										
YOX1150	600	265-615	1.5-1.8	2-2.5	0.96	ϕ 1312	850	ϕ 170/300	ϕ 170/300	85	170	810
	750	525-1195										
YOX1250	500	235-540	1.5-1.8	2-2.5	0.96	ϕ 1420	940	ϕ 200/300	ϕ 200/300	110	210	960
	600	400-935										
YOX1320	750	800-1800	1.5-1.8	2-2.5	0.96	ϕ 1500	1050	ϕ 210/320	ϕ 210/320	128	230	1080
	500	315-710										
	600	650-1200										
	750	1050-2360										



一流产品 一流服务
First-class products First-class service



HENAN MODERN INDUSTRIAL, CO LIMITED

ADD: NO.8 Linke ROAD, ZHENGZHOU, HENAN PROVINCE. CHINA Postcode: 450000

TEL: + 86-371-88881695 FAX: + 86-371-88881697 WEB: WWW.BRAKE.HK

YOXA型结构图及主要技术参数：（YOXE、TVAE同结构型）
YOXA Type Structural Drawing and Main Technical Date: (YOXE、TVAE The same structure type)

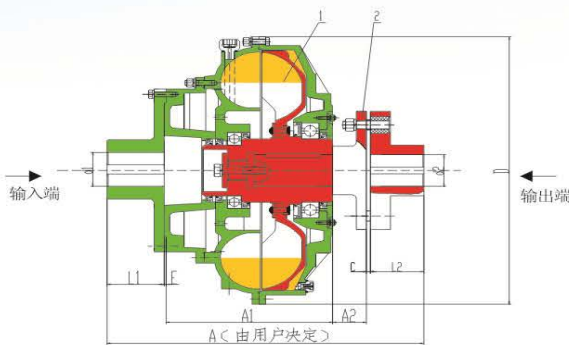

传动形式二：

单腔型外轮驱动带弹性套柱销联轴器

- 1、液力耦合器
- 2、弹性套柱销联轴器

Transmission II:

Single cavity outer-wheel drive type with shaft coupling pin in elastic sleeve.

1. Hydraulic power coupler
2. Shaft coupling with pin in elastic sleeve

规格型号 Specification Type	输入转速 Input speed (r/min)	传递功率范围 Range of power transmitted (kw)	过载系数(Tg) Over load coeff		效率 Effic iency η	外型尺寸 Dimensions					最大输入孔径及长度 Max. Input bore diameter & length (d1/L2)	弹性套柱销联轴器 Shaft coupling with pin in elastic sleeve GB4823-84			充油量 (L) Volume of filling oil		重量 Weight (Kg)
			起动 start	制动 brake		D	A1	A2	C	E		型号 type	d2max	L2max	40% qmin	80% qmax	
YOXA360	1000	5-10	1.5-1.8	2-2.5	0.96	φ 415	229	55	8	6	φ 55/110	TL5	φ 55	112	3.4	6.7	50
	1500	16-30										TL6					
YOXA400	1000	8-18.5	1.5-1.8	2-2.5	0.96	φ 465	256	65	8	6	φ 65/140	TL6	φ 65	142	5.2	10.4	78
	1500	28-48										TL7					
YOXA450	1000	15-30	1.5-1.8	2-2.5	0.96	φ 520	292	65	8	6	φ 75/140	TL7	φ 75	142	7.5	15	96
	1500	50-90										TL8					
YOXA500	1000	25-50	1.5-1.8	2-2.5	0.96	φ 582	316	85	10	6	φ 95/170	TL8	φ 95	172	10.3	20.5	128
	1500	68-144										TL10					
YOXA560	1000	40-80	1.5-1.8	2-2.5	0.96	φ 634	350	85	10	6	φ 120/210	TL9	φ 120	212	13.2	26.4	183
	1500	120-270										TL10					
YOXA600	1000	60-115	1.5-1.8	2-2.5	0.96	φ 695	380	110	12	8	φ 120/210	TL10	φ 120	212	16.8	33.6	222
	1500	200-360										TL11					
YOXA650	1000	90-176	1.5-1.8	2-2.5	0.96	φ 760	425	110	12	8	φ 150/250	TL10	φ 150	252	24	48	276
	1500	260-480										TL11					
YOXA750	1000	170-330	1.5-1.8	2-2.5	0.96	φ 860	450	125	12	8	φ 150/250	TL11	φ 150	252	34	68	420
	1500	380-760										TL12					
YOXA875	750	140-280	1.5-1.8	2-2.5	0.96	φ 992	514	125	12	8	φ 150/250	TL11	φ 150	252	56	112	594
	1000	330-620										TL12					
YOXA1000	600	160-300	1.5-1.8	2-2.5	0.96	φ 1138	579	150	15	10	φ 150/250	TL12	φ 150	252	74	147	780
	750	260-590										TL13					
YOXA1150	600	265-615	1.5-1.8	2-2.5	0.96	φ 1312	669	150	15	10	φ 170/300	TL12	φ 170	302	85	170	972
	750	525-1195										TL13					
YOXA1250	500	235-540	1.5-1.8	2-2.5	0.96	φ 1420	767	170	15	12	φ 200/300	TL13	φ 200	302	110	210	1150
	600	400-935										TL14					
YOXA1320	500	315-710	1.5-1.8	2-2.5	0.96	φ 1500	855	170	15	12	φ 210/310	TL14	φ 210	322	128	230	1265
	600	650-1200										TL15					
	750	1050-2360															

说明: YOX A型为单腔型外轮驱动带弹性套柱销联轴器，其特点为：
1、安装后需拆卸偶合器时，不用移动电机和减速机，只需拆去弹性柱销和连接盘与偶合器的联结螺栓，再将偶合器向输出端移动便可吊出。
2、此类液力耦合器易于找正、安装、拆卸。

Notes: Model YOX A is single cavity type external wheel driving belt elastic case axle-pin coupler. Its characteristics are:
1) After installation, when the coupler is needed to be removed, it is not necessary to move electric motor and decelerometer, is only necessary to remove the elastic pin and the linking bolt of connection plate and coupler, after that, move the coupler to ward the output end, then the coupler may be lifted out.
2) Such hydraulic power couplers are easy to be captured, installed and removed.



一流产品 一流服务
First-class products First-class service



HENAN MODERN INDUSTRIAL, CO LIMITED

ADD: NO.8 Linke ROAD, ZHENGZHOU, HENAN PROVINCE. CHINA Postcode: 450000

TEL: + 86-371-88881695 FAX: + 86-371-88881697 WEB: WWW.BRAKE.HK

YOXAZ型结构图及主要技术参数：（YOXEZL同结构型）

YOXAZ Type Structural Drawing and Main Technical Date:(YOXEZL The same structure type)

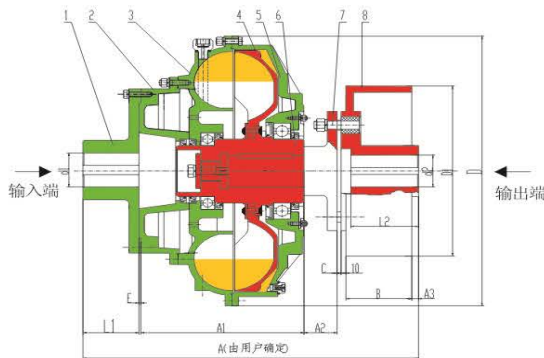

传动形式三：

- 1、连接盘
- 2、后辅腔
- 3、泵轮
- 4、涡轮
- 5、外壳
- 6、主轴
- 7、弹性套柱销联轴器
- 8、制动轮

Transmission III:

- 1.Holding Disc
- 2.Delay chamber
- 3.Pump wheel
- 4.Turbo wheel
- 5.Shell
- 6.Shaft
- 7.Shaft coupling with pin in elastic sleeve
- 8.Brake wheel

规格型号 Specification type	输入转速 Input speed (r/min)	传递功率范围 Range of power transmitted (kw)	过载系数(Tg) Over load coeff		效率 Effic iency η	外型尺寸 Dimensions					最大输入孔径及长度 Max.Input bore diameter & length (d1/L2)	弹性套柱销联轴器 Shaft coupling with pin in elastic sleeve GB4823-84		充油量 (L) Volume of filling oil		重量 Weight 不含制动轮重量 (KG)	
			起动 start	制动 brake		D	A1	A2	C	E		型号 type	d2max	L2max	40% min		80% max
YOXAz360	1000	5-10	1.5-1.8	2-2.5	0.96	φ 415	229	55	8	6	φ 55/110	TL5	φ 55	112	3.3	6.7	50
	1500	16-30										TL6					
YOXAz400	1000	8-18.5	1.5-1.8	2-2.5	0.96	φ 465	256	65	8	6	φ 65/140	TL6	φ 65	142	5.2	10.4	78
	1500	28-48										TL7					
YOXAz450	1000	15-30	1.5-1.8	2-2.5	0.96	φ 520	292	65	8	6	φ 75/140	TL7	φ 75	142	7.5	15	96
	1500	50-90										TL8					
YOXAz500	1000	25-50	1.5-1.8	2-2.5	0.96	φ 582	316	85	10	6	φ 95/170	TL8	φ 95	172	10.3	20.6	128
	1500	68-144										TL10					
YOXAz560	1000	40-80	1.5-1.8	2-2.5	0.96	φ 634	350	85	10	6	φ 120/210	TL9	φ 120	212	13.2	26.4	183
	1500	120-270										TL10					
YOXAz600	1000	60-115	1.5-1.8	2-2.5	0.96	φ 695	380	110	12	8	φ 120/210	TL10	φ 120	212	16.8	33.6	222
	1500	200-360										TL11					
YOXAz650	1000	90-176	1.5-1.8	2-2.5	0.96	φ 760	425	110	12	8	φ 150/250	TL10	φ 150	252	24	48	276
	1500	260-480										TL11					
YOXAz750	1000	170-330	1.5-1.8	2-2.5	0.96	φ 860	450	125	12	8	φ 150/250	TL11	φ 150	252	34	68	420
	1500	380-760										TL12					
YOXAz875	750	140-280	1.5-1.8	2-2.5	0.96	φ 992	514	125	12	8	φ 150/250	TL11	φ 150	252	56	112	594
	1000	330-620										TL12					
YOXAz1000	600	160-280	1.5-1.8	2-2.5	0.96	φ 1138	579	150	15	10	φ 150/250	TL11	φ 150	252	74	147	780
	750	260-590										TL12					
YOXAz1150	600	265-615	1.5-1.8	2-2.5	0.96	φ 1312	669	150	15	10	φ 170/300	TL12	φ 170	302	85	170	971
	750	525-1195										TL13					
YOXAz1250	500	235-540	1.5-1.8	2-2.5	0.96	φ 1420	767	170	15	12	φ 200/300	TL13	φ 200	302	110	210	1151
	600	400-935										TL14					
	750	800-1800										TL14					
YOXAz1320	500	315-710	1.5-1.8	2-2.5	0.96	φ 1500	855	170	15	12	φ 210/310	TL14	φ 210	322	128	230	1268
	600	650-1200										TL15					
	750	1050-2360															

说明:YOXAz型为带动制轮耦合器型,其特点为:

- 1、安装后需拆卸耦合器时,不用移动电机和减速机,只需拆去弹性柱销和连接盘与耦合器的联结螺栓,在将耦合器向制轮端移动便可吊出。
- 2、此类液力耦合器易于找正、安装、拆卸。
- 3、制轮尺寸可另行商议。

Notes:YOXAz is belt drive triggering coupler type, its characteristics are:

- 1) After installation, when it is needed to remove the coupler, it is not necessary to move electric motor and decelerometer, it is only needed to remove the elastic pin and the connection bolt of linking plate and coupler, after that, move the coupler to wards the end of brake wheel, then the coupler may be lifted out.
- 2) Such hydraulic power couplers are easy to be captured and removed.
- 3) The dimensions of brake wheel may be consulted separately.



一流产品 一流服务
First-class products First-class service



HENAN MODERN INDUSTRIAL, CO LIMITED

ADD: NO.8 Linke ROAD, ZHENGZHOU, HENAN PROVINCE. CHINA Postcode: 450000

TEL: + 86-371-88881695 FAX: + 86-371-88881697 WEB: WWW.BRAKE.HK

YOX_N型结构图及主要技术参数：(YOXL.YOX_R.YOX_p.TVAL同结构型)
Model YOX_N structure drawing and major technological parameters: (YOXL.YOX_R.YOX_p.TVAL the same structure type)

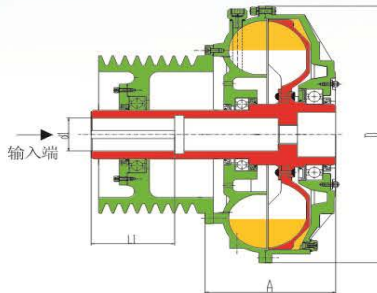

传动形式四：

说明：YOX_N型为限矩形通用结构形式，其特点为：

- 1.用于垂直传动场合，一般为内轮传动。
- 2.皮带轮形式与尺寸按用户需求定。

Transmission form IV:

Note: Model YOX_N is limited rectangular universal structure type, its characteristics are:

- 1) It is used in vertical transmission place, it is generally internal wheel transmission
- 2) Belt-wheel type and dimension are decided according to the requirement of customers.

规格型号 Specifacaton type	输入转速 Input speed (r/min)	传递功率 范围 Range of Power Transmitted (KW)	过载系数 (T _g) Over load coeff		效率 Effe lency η	外型尺寸 Dimensions (mm)		最大输入孔 径及长度 Max.Input bore Diameter Length (d/A1)	充油量 (L) Volume of Filling oil		重量 weight 不含皮带 轮重量 (KG)
			起动 stat	制动 brake		D	A		qmin40%	qmax80%	
YOX _N 150	1000	0.05-0.2	2-2.7	2-2.7	0.97	φ 195	115	φ 25/40	0.2	0.42	6
	1500	0.2-0.55									
YOX _N 180	1000	0.1-0.3	2-2.7	2-2.7	0.97	φ 232	125	φ 30/50	0.24	0.48	7
	1500	0.5-1.1									
YOX _N 200	1000	0.2-0.55	2-2.7	2-2.7	0.97	φ 254	128	φ 35/60	0.6	1.2	8.8
	1500	0.8-2.2									
YOX _N 220	1000	0.4-1.1	2-2.7	2-2.7	0.97	φ 278	136	φ 40/80	0.76	1.52	13
	1500	1.5-3									
YOX _N 250	1000	0.8-1.5	2-2.7	2-2.7	0.97	φ 305	156	φ 45/80	1.1	2.1	16
	1500	2.5-5.5									
YOX _N 280	1000	1.5-3	2-2.7	2-2.7	0.97	φ 345	164	φ 50/80	1.4	2.8	21
	1500	4.5-8									
YOX _N 320	1000	2.5-5.5	2-2.7	2-2.7	0.97	φ 380	179	φ 55/110	2.2	4.4	28
	1500	9-18.5									
YOX _N 340	1000	3-9	2-2.7	2-2.7	0.97	φ 390	187	φ 55/110	2.7	5.3	36
	1500	12-22									
YOX _N 360	1000	5-10	1.5-1.8	2-2.5	0.96	φ 415	229	φ 60/110	3.4	6.7	42
	1500	16-30									
YOX _N 400	1000	8-18.5	1.5-1.8	2-2.5	0.96	φ 465	256	φ 70/140	5.2	10.4	65
	1500	28-48									
YOX _N 450	1000	15-30	1.5-1.8	2-2.5	0.96	φ 520	292	φ 75/140	7.5	15	79
	1500	50-90									
YOX _N 500	1000	25-50	1.5-1.8	2-2.5	0.96	φ 582	316	φ 90/170	10.3	20.5	105
	1500	68-144									
YOX _N 560	1000	40-80	1.5-1.8	2-2.5	0.96	φ 634	350	φ 100/210	13.2	26.4	152
	1500	120-270									
YOX _N 600	1000	60-115	1.5-1.8	2-2.5	0.96	φ 695	380	φ 100/210	16.8	33.6	185
	1500	200-360									
YOX _N 650	1000	90-176	1.5-1.8	2-2.5	0.96	φ 760	425	φ 120/210	24	48	230
	1500	260-480									
YOX _N 750	1000	170-330	1.5-1.8	2-2.5	0.96	φ 860	450	φ 120/210	34	68	350
	1500	380-760									
YOX _N 875	750	140-280	1.5-1.8	2-2.5	0.96	φ 992	514	φ 150/250	56	112	495
	1000	330-620									
YOX _N 1000	600	160-300	1.5-1.8	2-2.5	0.96	φ 1138	577	φ 150/250	74	148	650
	750	260-590									
YOX _N 1150	600	265-615	1.5-1.8	2-2.5	0.96	φ 1312	669	φ 170/300	85	170	810
	750	525-1195									
YOX _N 1250	500	235-540	1.5-1.8	2-2.5	0.96	φ 1420	767	φ 200/300	110	210	960
	600	400-935									
YOX _N 1320	750	800-1800	1.5-1.8	2-2.5	0.96	φ 1500	855	φ 210/320	128	230	1080
	500	315-710									
	600	650-1200									
	750	1050-2360									



一流产品 一流服务
First-class products First-class service



HENAN MODERN INDUSTRIAL, CO LIMITED

ADD: NO.8Linke ROAD, ZHENGZHOU, HENAN PROVINCE. CHINA Postcode: 450000
TEL: + 86-371-88881695 FAX: + 86-371-88881697 WEB: WWW.BRAKE.HK

YOX_{NZ}型结构图及主要技术参数：（YOX_{FZ}.YOX_{ZL}同结构型）
YOX_{NZ} Type Structural Drawing and Main Technical Date:(YOX_{FZ}.YOX_{ZL}the same stucture type)

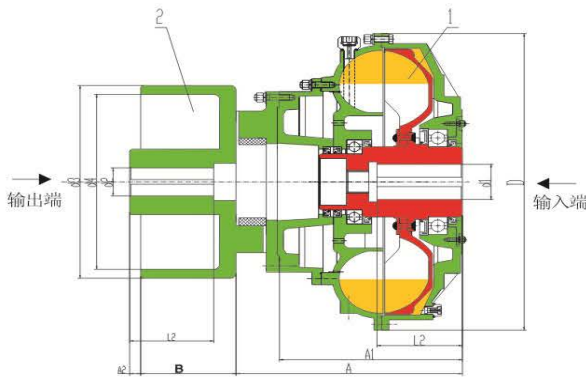

传动形式五：

单腔内轮驱动带制动轮型
1、液力偶合器
2、制动轮

Transmission V:

Single cavity inner-wheel drive type with brake wheel
1.Hydraulic power coupler
2.Brake wheel

规格型号 Specifacaton type	输入 转速 Input speed (r/min)	传递功率 范围 Range of power transmitted (kw)	过载系数(Tg)		效率 Effic iency η	外型尺寸 Dimensions				最大输入孔 径及长度 Max.Input bore diameter &length (d1/l1)	最大输出孔 径及长度 Max.output bore diameter &length (d2/l2)	充油量 (L) Volume of filling oil		重量 Weight 不含制动 轮重量 (KG)	制动轮外型尺寸 Dimensions of brake wheel		
			起动 start	制动 brake		D	A	A1	A2			40% min	80% max		d3	d4	B
YOX _{NZ} 200	1000 1500	0.2-0.55 0.8-2	2-2.7	2-2.7	0.97	ϕ 254	158	128	10	ϕ 30/60	ϕ 35/60	0.6	1.2	7	按 用 户 提 供 尺 寸 加 工		
YOX _{NZ} 220	1000 1500	0.4-1.1 1.5-3	2-2.7	2-2.7	0.97	ϕ 278	166	136	10	ϕ 35/80	ϕ 40/80	0.8	1.6	11			
YOX _{NZ} 250	1000 1500	0.8-1.5 2.5-5.5	2-2.7	2-2.7	0.97	ϕ 305	196	156	10	ϕ 40/80	ϕ 45/80	1.1	2.2	13			
YOX _{NZ} 280	1000 1500	1.5-3 4.5-8	2-2.7	2-2.7	0.97	ϕ 345	207	162	10	ϕ 45/110	ϕ 50/80	1.4	2.8	16			
YOX _{NZ} 320	1000 1500	2.5-5.5 9-18.5	2-2.7	2-2.7	0.97	ϕ 380	228	179	10	ϕ 50/110	ϕ 55/110	2.2	4.4	22			
YOX _{NZ} 340	1000 1500	3-9 12-22	2-2.7	2-2.7	0.97	ϕ 390	247	187	10	ϕ 50/110	ϕ 55/110	2.7	5.4	30			
YOX _{NZ} 360	1000 1500	5-10 16-30	1.5-1.8	2-2.5	0.96	ϕ 415	282	229	10	ϕ 55/110	ϕ 60/110	3.4	6.8	35			
YOX _{NZ} 400	1000 1500	8-18.5 28-48	1.5-1.8	2-2.5	0.96	ϕ 465	316	256	10	ϕ 65/140	ϕ 70/140	5.2	10.4	56			
YOX _{NZ} 450	1000 1500	15-30 50-90	1.5-1.8	2-2.5	0.96	ϕ 520	358	292	10	ϕ 70/140	ϕ 75/140	7.5	15	69			
YOX _{NZ} 500	1000 1500	25-50 68-144	1.5-1.8	2-2.5	0.96	ϕ 582	387	316	15	ϕ 90/170	ϕ 90/170	10.3	20.6	88			
YOX _{NZ} 560	1000 1500	40-80 120-270	1.5-1.8	2-2.5	0.96	ϕ 634	425	350	15	ϕ 100/210	ϕ 100/210	13.2	26.4	130			
YOX _{NZ} 600	1000 1500	60-115 200-360	1.5-1.8	2-2.5	0.96	ϕ 695	463	380	15	ϕ 100/210	ϕ 100/210	16.8	33.6	165			
YOX _{NZ} 650	1000 1500	90-176 260-480	1.5-1.8	2-2.5	0.96	ϕ 760	510	425	15	ϕ 130/210	ϕ 130/210	21	48	207			
YOX _{NZ} 750	1000 1500	170-330 380-760	1.5-1.8	2-2.5	0.96	ϕ 860	548	450	20	ϕ 150/250	ϕ 140/250	34	68	314			
YOX _{NZ} 875	750 1000	140-280 330-620	1.5-1.8	2-2.5	0.96	ϕ 992	620	514	20	ϕ 150/250	ϕ 150/250	56	112	460			
YOX _{NZ} 1000	600 750	160-300 260-590	1.5-1.8	2-2.5	0.96	ϕ 1138	702	577	20	ϕ 150/250	ϕ 150/250	74	148	610			
YOX _{NZ} 1150	600 750	265-615 525-1195	1.5-1.8	2-2.5	0.96	ϕ 1312	780	669	20	ϕ 170/300	ϕ 170/300	85	170	760			
YOX _{NZ} 1250	500 600 750	235-540 400-935 800-1800	1.5-1.8	2-2.5	0.96	ϕ 1420	892	758	25	ϕ 200/300	ϕ 200/300	110	210	890			
YOX _{NZ} 1320	500 600 750	315-710 650-1200 1050-2360	1.5-1.8	2-2.5	0.96	ϕ 1500	1015	855	25	ϕ 210/320	ϕ 210/320	128	230	1000			

说明：YOX_{NZ}型为单腔内轮驱动带制动轮型，其特点为：这种传动形式适用于带制动机构的驱动单元，使其结构简单、紧凑。

Notes: Model YOX_{NZ} is of single cavity internal-wheel drive with brake wheel type, its characteristics are: such type of transmission is suit to the driving unit with brake machine structure, making it with simple and compact structure.



HENAN MODERN INDUSTRIAL, CO LIMITED

ADD: NO.8 Linke ROAD, ZHENGZHOU, HENAN PROVINCE, CHINA Postcode: 450000

TEL: + 86-371-88881695 FAX: + 86-371-88881697 WEB: WWW.BRAKE.HK

YOX II Z 型结构图及主要技术参数:

YOX II Z Type Structural Drawing and Main Technical Date:

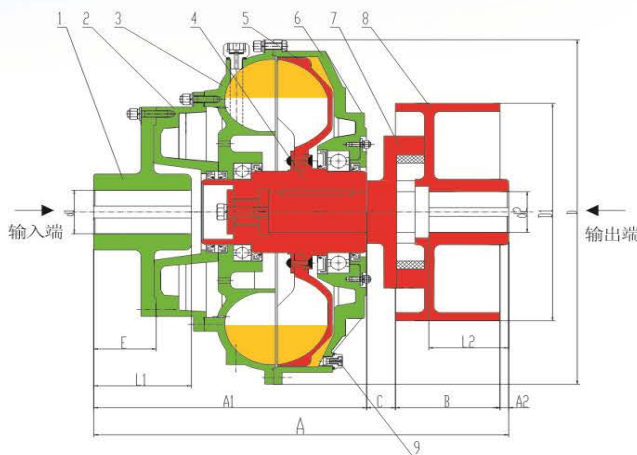

传动形式六: Transmission VI:

- | | |
|---------|------------------------|
| 1.连接盘 | 1.Holding Disc |
| 2.后辅腔 | 2.Delay chamber |
| 3.泵轮 | 3.Outer wheel |
| 4.主轴 | 4.Hub |
| 5.涡轮 | 5.Inner wheel |
| 6.外壳 | 6.Shell |
| 7.连接轴 | 7.Connection shaft |
| 8.制动轮 | 8.Brake wheel |
| 9.特殊易熔塞 | 9.Special fusible plug |

规格型号 Specification type	输入转速 Input speed (r/min)	传递功率 范围 Range of power transmitted (kw)	过载系数(Tg)		效率 Efficiency η	外型尺寸 Dimensions(mm)								最大输入孔径及长度 Max.Input bore diameter & length (d1/L1)	最大输出孔径及长度 Max.output bore diameter & length (d2/L2)	充油量 (L)		重量 Weight (KG)
			起动 start	制动 brake		D	A	A1	B	D1	A2	C	E			40% min	80% max	
YOX II Z400	1000	8-18.5	1.5-1.8	2-2.5	0.96	φ 465	556	358	150	φ 315	10	38	101	φ 65/140	φ 65/140	5.2	10.4	115
	1500	28-48																
YOX II Z450	1000	15-30	1.5-1.8	2-2.5	0.96	φ 520	580	382	150	φ 315	10	38	90	φ 75/140	φ 75/140	7.5	15	128
	1500	50-90																
YOX II Z500	1000	25-50	1.5-1.8	2-2.5	0.96	φ 582	664	423	190	φ 400	10	41	107	φ 90/170	φ 90/170	10.3	20.5	156
	1500	68-144																
YOX II Z560	1000	40-80	1.5-1.8	2-2.5	0.96	φ 634	736	491	190	φ 400	10	45	141	φ 100/210	φ 100/210	13.2	26.4	205
	1500	120-270																
YOX II Z600	1000	60-115	1.5-1.8	2-2.5	0.96	φ 695	790	520	210	φ 500	15	45	140	φ 110/210	φ 110/210	16.8	33.6	260
	1500	200-360																
YOX II Z650	1000	90-176	1.5-1.8	2-2.5	0.96	φ 760	829	560	210	φ 500	15	45	134	φ 120/210	φ 120/210	24	48	386
	1500	260-480																
YOX II Z750	1000	170-330	1.5-1.8	2-2.5	0.96	φ 860	940	610	265	φ 630	15	50	160	φ 130/210	φ 130/210	34	68	488
	1500	380-760																
YOX II Z875	750	140-280	1.5-1.8	2-2.5	0.96	φ 992	1040	680	265	φ 630	20	75	160	φ 140/250	φ 140/250	56	112	655
	1000	330-620																

说明: 1、YOX II Z型为带制动轮, 用于需要制动场合, 外轮驱动, 结构紧凑。

2、所有尺寸全行业均已统一。

3、制动轮尺寸可另行协商。

Notes: 1) Model YOX II Z is with brake wheel, is used where brake is needed, It is driven by external wheel with compact structure.

2) All the sizes are uniformed in the whole trade.

3) The sizes of brake wheel may be consulted separately.



一流产品 一流服务
First-class products First-class service



HENAN MODERN INDUSTRIAL, CO LIMITED

ADD: NO.8Linke ROAD, ZHENGZHOU, HENAN PROVINCE. CHINA Postcode: 450000

TEL: + 86-371-88881695 FAX: + 86-371-88881697 WEB: WWW.BRAKE.HK

YOXv型结构图及主要技术参数：（YOX_Y同结构型）

YOXv Type Structural Drawing and Main Technical Date:(YOX_Y the same structure type)

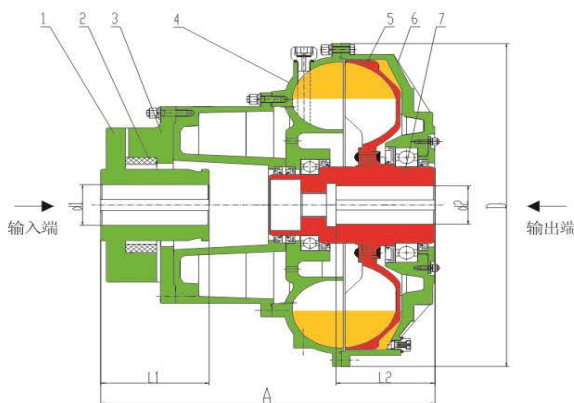

传动形式七:

- 1.主动节
- 2.从动节
- 3.加长后辅腔
- 4.泵轮
- 5.涡轮
- 6.外壳
- 7.主轴

Transmission VII:

- 1.Driving Connection
- 2.Driven Connection
- 3.Longer Delay chamber
- 4.Outer Wheel
- 5.Inner Wheel
- 6.Shell
- 7.Coupling Hub

规格型号 Specification Type	输入转速 Input speed n(r.p.m)	传递功率 范围 Ranger of power transmitted N (KW)	过载系数 Over load Coeff Tg		效率 Effic iency η	外型尺寸 (mm) Dimensions (mm)		最大输入孔 径及长度 Max.Input bore diameter & Length $\frac{d_{imax}}{L_{imax}}$	最大输出孔 径及长度 Max.output bore diameter & Length $\frac{d_{max}}{L_{max}}$	充油量 q (L) Volume of filling oil		重量 p (kg)
			起动 start	制动 brake		40% qmin	72% qmax					
YOXv360	1000	5-10	1.35-1.5	2-2.3	0.96	ϕ 428	360	ϕ 60 110	ϕ 55 110	3.8	6.8	47
	1500	16-30										
YOXv400	1000	8-18.5	1.35-1.5	2-2.3	0.96	ϕ 472	390	ϕ 70 140	ϕ 60 140	5.8	10.4	71
	1500	28-48										
YOXv450	1000	15-30	1.35-1.5	2-2.3	0.96	ϕ 530	445	ϕ 75 140	ϕ 70 140	8.3	15	88
	1500	50-90										
YOXv500	1000	25-50	1.35-1.5	2-2.3	0.96	ϕ 582	510	ϕ 90 170	ϕ 90 170	11.4	20.6	115
	1500	68-144										
YOXv560	1000	40-80	1.35-1.5	2-2.3	0.96	ϕ 634	530	ϕ 100 210	ϕ 100 210	14.6	26.4	164
	1500	120-270										
YOXv600	1000	60-115	1.35-1.5	2-2.3	0.96	ϕ 695	575	ϕ 100 210	ϕ 100 210	18.6	33.6	200
	1500	200-360										
YOXv650	1000	90-176	1.35-1.5	2-2.3	0.96	ϕ 760	650	ϕ 130 210	ϕ 130 210	26.6	48	240
	1500	260-480										
YOXv750	1000	170-330	1.35-1.5	2-2.3	0.96	ϕ 860	680	ϕ 140 250	ϕ 150 250	37.7	68	375
	1500	380-760										
YOXv875	750	140-280	1.35-1.5	2-2.3	0.96	ϕ 992	820	ϕ 150 250	ϕ 150 250	62.1	112	530
	1000	330-620										
YOXv1000	600	160-300	1.35-1.5	2-2.3	0.96	ϕ 1138	845	ϕ 150 250	ϕ 150 250	82.5	148	710
	750	260-590										
YOXv1150	600	265-615	1.35-1.5	2-2.3	0.96	ϕ 1312	885	ϕ 170 300	ϕ 170 300	95	170	880
	750	525-1195										
YOXv1250	500	235-540	1.35-1.5	2-2.3	0.96	ϕ 1420	960	ϕ 200 300	ϕ 200 300	120	210	1030
	600	400-935										
	750	800-1800										
YOXv1320	500	315-710	1.35-1.5	2-2.3	0.96	ϕ 1500	975	ϕ 210 310	ϕ 210 310	140	230	1130
	600	650-1200										
	750	1050-2360										

说明:YOXv型为加长后辅腔结构,其特点是较YOX型延长了起动时间,一般为22-30秒,对要求降低起动力矩、延长起动时间,提高胶带使用寿命的胶带输送机,特别适用。

Notes:YOXv makes longer of the delay chamber in structure. The features is to longer the starting time,About 22-30s,Its very fixed to improve the time of the belt conveyor, delay the starting time, ect.



一流产品 一流服务
First-class products First-class service



HENAN MODERN INDUSTRIAL, CO LIMITED

ADD: NO.8 Linke ROAD, ZHENGZHOU, HENAN PROVINCE. CHINA Postcode: 450000

TEL: + 86-371-88881695 FAX: + 86-371-88881697 WEB: WWW.BRAKE.HK

YOX_{VA}型结构图及主要技术参数:

YOX_{VA} Type Structural Drawing and Main Technical Date:

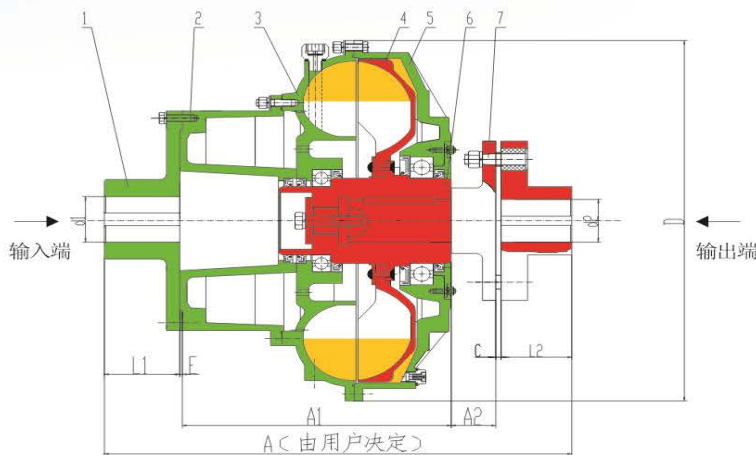

传动形式八:

1. 连接盘
2. 加长后辅腔
3. 泵轮
4. 涡轮
5. 外壳
6. 主轴
7. 弹性套柱销联轴器

Transmission VII:

1. Holding disc
2. Longer delay chamber
3. Outer wheel
4. Inner wheel
5. Shell
6. Shaft
7. Shaft coupling with pin in elastic sleeve

规格型号 Specification Type	输入转速 Input speed n(r.p.m)	传递功率 范围 Ranger of power transmitted (KW)	过载系数 Over load coeff Tg		效率 Effic ency	外型尺寸 (mm) Dimensions (mm)					最大输入孔 径及长度 Max.input bore diameter & Length d _{max} L _{max}	弹性套柱销联轴器 Shaft coupling with pin in elastic sleeve GB323-84		充油量q (L) Volume of filling oil		重量 Weight (kg)	
			起动 start	制动 brake		D	A ₁	A ₂	C	E		Type	d _{max}	L _{max}	40% q _{min}		80% q _{max}
YOXVA360	1000	5-10	1.1-1.35	2-2.3	0.96	φ428	278	55	8	6	φ55 110	TL5	φ55	112	3.8	6.8	60
	1500	16-30										TL6					
YOXVA400	1000	8-18.5	1.1-1.35	2-2.3	0.96	φ472	308	65	8	6	φ65 140	TL6	φ65	142	5.8	10.4	90
	1500	28-48										TL7					
YOXVA450	1000	15-30	1.1-1.35	2-2.3	0.96	φ530	353	65	8	6	φ75 140	TL7	φ75	142	8.3	15	112.5
	1500	50-90										TL8					
YOXVA500	1000	25-50	1.1-1.35	2-2.3	0.96	φ582	391	85	10	6	φ95 170	TL8	φ95	172	11.4	20.6	155.5
	1500	68-144										TL10					
YOXVA560	1000	40-80	1.1-1.35	2-2.3	0.96	φ634	433	85	10	6	φ120 210	TL9	φ120	212	14.6	26.4	242
	1500	120-270										TL10					
YOXVA600	1000	60-115	1.1-1.35	2-2.3	0.96	φ695	467	110	12	8	φ120 210	TL10	φ120	212	18.6	33.6	257
	1500	200-360										TL11					
YOXVA650	1000	90-176	1.1-1.35	2-2.3	0.96	φ760	520	110	12	8	φ150 250	TL10	φ150	252	26.6	48	306
	1500	260-480										TL11					
YOXVA750	1000	170-330	1.1-1.35	2-2.3	0.96	φ860	550	125	12	8	φ150 250	TL11	φ150	252	37.7	68	476
	1500	380-760										TL12					
YOXVA875	750	140-280	1.1-1.35	2-2.3	0.96	φ992	632	125	12	8	φ150 250	TL11	φ150	252	62.1	112	679
	1000	330-620										TL12					
YOXVA1000	600	160-300	1.1-1.35	2-2.3	0.96	φ1138	692	150	15	10	φ150 250	TL12	φ150	252	82.5	148	910
	750	260-590										TL13					

说明: 此结构的特点为:

- 1、YOX_{VA}为带加长后辅腔结构,特点是起动时间长,一般为22-30秒,对要求延长起动时间,提高胶带寿命的胶带输送机特别适用。
- 2、安装后需拆卸耦合器时,不用移动电机和减速机。只需拆去弹性柱销和连接盘与加长后辅腔的联接螺栓,再将耦合器向输出端移动便可吊出。

Notes: This form has following features:

- 1、YOX_{VA} makes longer of the delay chamber with brake wheel in output side, in structre. The feature is to longer the time of the starting time, about 22-30, its very fixed to improve the belt conveyor and delay the starting time.
- 2、It doesnt need to move motor and reducer during dismounting coupliremove the flexit pin and bolt which connects the Holing disc and linger delay chamber, then move couplings output to hang it up.



一流产品 一流服务
First-class products First-class service



HENAN MODERN INDUSTRIAL, CO LIMITED

ADD: NO.8 Linke ROAD, ZHENGZHOU, HENAN PROVINCE. CHINA Postcode: 450000

TEL: + 86-371-88881695 FAX: + 86-371-88881697 WEB: WWW.BRAKE.HK

YOXVAZ型结构图及主要技术参数：（YOXYEZ同结构型）

YOXVAZ Type Structural Drawing and Main Technical Date:(YOXYEZ the same structure type)

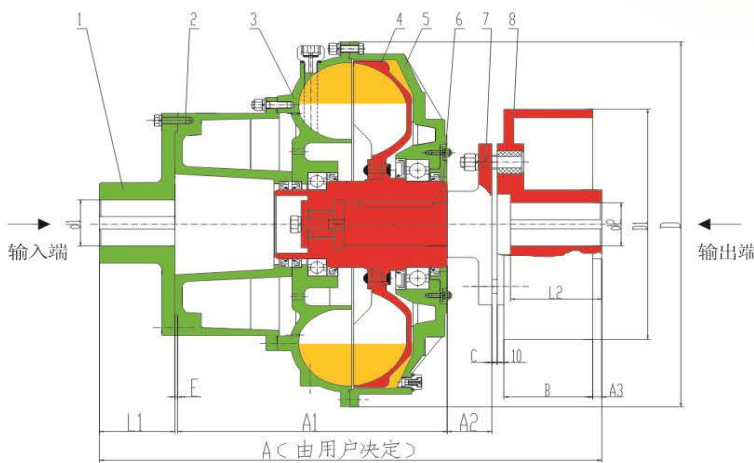

传动形式九：

- 1.连接盘
- 2.加长后辅腔
- 3.泵轮
- 4.涡轮
- 5.外壳
- 6.主轴
- 7.弹性套柱销联轴器
- 8.制动轮

Transmission IX:

- 1.Holding disc
- 2.Longer delay chamber
- 3.Pump wheel
- 4.Turbo wheel
- 5.Shell
- 6.Shaft
- 7.Shaft coupling with pin in elastic sleeve
- 8.Brake wheel

规格型号 Specification Type	输入转速 Input speed n(r.p.m)	传递功率 范围 Ranger of power transmitted N (KW)	过载系数 Overload coeff Tg		效率 Effic ency η	安装尺寸 (mm) Dimensions (mm)					弹性套柱销联轴器 Shaft coupling with pin in elastic sleeve		充油量 (L) Volume of filling oil		重量 Weight (kg)		
			起动 start	制动 brake		D	A ₁	A ₂	C	E	Type	d,max	L,max	q _{min} (L) 40%		q _{min} (L) 72%	
YOXVAZ360	1000	5-10	1.1-1.35	2-2.3	0.96	φ428	278	55	8	6	φ55	TL5	φ55	112	3.8	6.8	60
	1500	16-30									110	TL6					
YOXVAZ400	1000	8-18.5	1.1-1.35	2-2.3	0.96	φ472	308	65	8	6	φ65	TL6	φ65	142	5.8	10.4	90
	1500	28-48									140	TL7					
YOXVAZ450	1000	15-30	1.1-1.35	2-2.3	0.96	φ530	353	65	8	6	φ75	TL7	φ75	142	8.3	15	112.5
	1500	50-90									140	TL8					
YOXVAZ500	1000	25-50	1.1-1.35	2-2.3	0.96	φ582	391	85	10	6	φ95	TL8	φ95	172	11.4	20.6	155.5
	1500	68-144									170	TL10					
YOXVAZ560	1000	40-80	1.1-1.35	2-2.3	0.96	φ634	433	85	10	6	φ120	TL9	φ120	212	14.6	26.4	242
	1500	120-270									210	TL10					
YOXVAZ600	1000	60-115	1.1-1.35	2-2.3	0.96	φ695	467	110	12	8	φ120	TL10	φ120	212	18.6	33.6	291
	1500	200-360									210	TL11					
YOXVAZ650	1000	90-176	1.1-1.35	2-2.3	0.96	φ760	520	110	12	8	φ150	TL10	φ150	252	26.6	48	386
	1500	260-480									250	TL11					
YOXVAZ750	1000	170-330	1.1-1.35	2-2.3	0.96	φ860	550	125	12	8	φ150	TL11	φ150	252	37.7	68	500
	1500	480-760									250	TL12					
YOXVAZ875	750	140-280	1.1-1.35	2-2.3	0.96	φ992	632	125	12	8	φ150	TL11	φ150	252	62.1	112	690
	1000	330-620									250	TL12					

说明：此结构的特点为：

- 1、YOXVAZ为加长后辅腔、输出端带制动轮结构，特点是起动时间长，一般为22-30秒，对要求延长起动时间，提高胶带寿命的胶带输送机特别适用。
- 2、安装后需拆卸偶合器时，不用移动电机和减速机。只需拆去弹性柱销和连接盘与加长后辅腔的联接螺栓，再将偶合器向输出端移动便可吊出。

Notes: This form has following festures:

- 1、YOXVAZ makes longer of the delay chamber with brake wheel in output side, in structre. The feature is to longer the time of the starting time, about22-30,Its very fixed to improve the belt conveyor and delay the starting time.
- 2、It doesnt need to move motor and reducer during dismounting coupliremove the flexit pin and bolt which connects the Holing disc and longer delay chamber,then move couplings output to hang it up.

一流产品 一流服务

First-class products First-class service



HENAN MODERN INDUSTRIAL, CO LIMITED

ADD: NO.8 Linke ROAD, ZHENGZHOU, HENAN PROVINCE, CHINA Postcode: 450000

TEL: + 86-371-88881695 FAX: + 86-371-88881697 WEB: WWW.BRAKE.HK

YOXvnz型结构图及主要技术参数:

YOXvnz Type Structural Drawing and Main Technical Date:

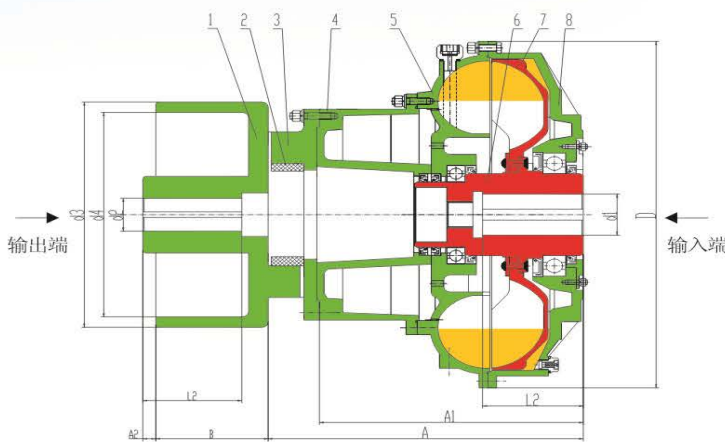

传动形式十:

1. 制动轮
2. 弹性胶块
3. 从动节
4. 加长后辅腔
5. 泵轮
6. 主轴
7. 涡轮
8. 外壳

Transmission X:

1. Brake wheel
2. Elastic block
3. Driven connection
4. Longer delay chamber
5. Pump wheel
6. Shaft
7. Turbo wheel
8. Shell

规格型号 Specification Type	输入转速 Input speed n(r.p.m)	传递功率 范围 Ranger of power transmitted N(KW)	过载系数 Over loadcoeff Tg		效率 Effic ieny η	外型尺寸 (mm) Dimensions (mm)				最大输入孔 径及长度 Max.input bore diameter & Length d,max/L,max	最大输出孔 径及长度 Max.output bore diameter & Length d,max/L,max	制动轮外形尺寸 Dimensions of brake wheel			充油量 (L) Volume offilling oil		重量 Weight (kg)
			启动 start	制动 brake		D	A	A ₁	A ₂			d ₃	d ₄	B	q _{max} (L) 40%	q _{max} (L) 80%	
YOXvnz360	1000	5-10	1.5-1.8	2-2.5	0.96	φ428	331	278	10	φ 55	φ 60	按用户 提供尺寸 加工	3.8	6.8	45		
	1500	16-30														110	110
YOXvnz400	1000	8-18.5	1.5-1.8	2-2.5	0.96	φ472	368	308	10	φ 60	φ 70		5.8	10.4	68		
	1500	28-48														120	140
YOXvnz450	1000	15-30	1.5-1.8	2-2.5	0.96	φ530	419	353	10	φ 70	φ 75		8.3	15	85.5		
	1500	50-90														140	140
YOXvnz500	1000	25-50	1.5-1.8	2-2.5	0.96	φ582	462	391	15	φ 90	φ 90		11.4	20.6	116		
	1500	68-144														170	170
YOXvnz560	1000	40-80	1.5-1.8	2-2.5	0.96	φ634	508	433	15	φ100	φ100		14.6	26.4	138		
	1500	120-270														210	210
YOXvnz600	1000	60-115	1.5-1.8	2-2.5	0.96	φ695	550	467	15	φ100	φ100	18.6	33.6	180			
	1500	200-360													210	210	
YOXvnz650	1000	90-176	1.5-1.8	2-2.5	0.96	φ760	605	520	15	φ130	φ130	26.6	48	237			
	1500	260-480													210	210	
YOXvnz750	1000	170-330	1.5-1.8	2-2.5	0.96	φ860	648	550	20	φ150	φ140	37.7	68	394			
	1500	380-760													250	250	
YOXvnz875	750	140-280	1.5-1.8	2-2.5	0.96	φ992	738	632	20	φ150	φ150	62.1	112	546			
	1000	330-620													250	250	

说明: 此结构的特点为:

- 1、YOXvnz为内轮驱动, 加长后辅腔、输出端带制动轮的结构。
- 2、适用于要求延长起动时间, 一般为22-30S带制动轮的驱动单元, 其结构简单、紧凑。

Notes: This form has following festures:

- 1、YOXvnz is inner-wheel drive type with the longer delay chamber and brake wheel in output side.
- 2、It is suitable for longer the time of the starting time, about 22-30S and driven unit with brake in structure which makes is simple and well-knit.



一流产品 一流服务
First-class products First-class service



HENAN MODERN INDUSTRIAL, CO LIMITED

ADD: NO.8 Linke ROAD, ZHENGZHOU, HENAN PROVINCE, CHINA Postcode: 450000

TEL: + 86-371-88881695 FAX: + 86-371-88881697 WEB: WWW.BRAKE.HK

YOXvIIz型结构图及主要技术参数：（YOXyz同结构型）

YOXvIIz Type Structural Drawing and Main Technical Date:(YOXyz the same structure type)

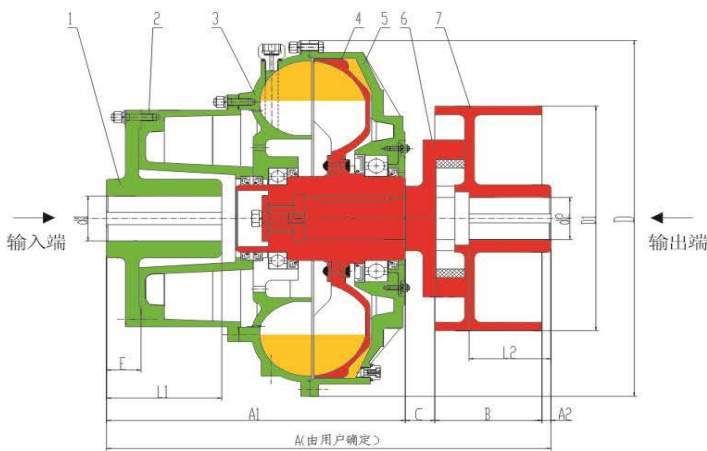

传动形式十一：

- 1.连接盘
- 2.加长后辅腔
- 3.泵轮
- 4.涡轮
- 5.外壳
- 6.连接轴
- 7.制动轮

Transmission XI:

- 1.Holding Disc
- 2.Longer Delay chamber
- 3.Outer Wheel
- 4.Inner wheel
- 5.Shell
- 6.Connecting Shaft
- 7.Brake wheel

规格型号 Specification Type	输入转速 Input speed n(r.p.m)	传递功率 范围 Ranger of power transmitted N (KW)	过载系数 Overload coeff Tg		效率 Effic iency η	最大输入孔径及长度 Max.Input bore diameter & Length d-max/L-max	最大输出孔径及长度 Max.output bore diameter & Length d2max/L2max	充油量 (L) Volume of filling oil		外型尺寸 (mm) Dimensions (mm)							重量 Weight (kg)	
			起动 start	制动 brake				40% qmin	80% qmax	A	A ₁	D	B	D ₁	A ₂	C		E
YOXvIIz400	1000	8-18.5	1.35-1.5	2-2.3	0.96	φ 65/140	φ 65/140	5.8	10.4	556	358	φ472	150	φ315	10	38	50	116
	1500	28-48																
YOXvIIz450	1000	15-30	1.35-1.5	2-2.3	0.96	φ 75/140	φ 75/140	8.3	15	581	383	φ530	150	φ315	10	38	30	132
	1500	50-90																
YOXvIIz500	1000	25-50	1.35-1.5	2-2.3	0.96	φ 90/170	φ 90/170	11.4	20.6	672	431	φ582	190	φ400	10	41	40	165
	1500	68-144																
YOXvIIz560	1000	40-80	1.35-1.5	2-2.3	0.96	φ 110/210	φ 110/210	14.6	26.4	748	503	φ634	190	φ400	10	45	70	210
	1500	120-270																
YOXvIIz600	1000	60-115	1.35-1.5	2-2.3	0.96	φ 110/210	φ 110/210	18.6	33.6	787	517	φ695	210	φ500	15	45	50	350
	1500	200-360																
YOXvIIz650	1000	90-176	1.35-1.5	2-2.3	0.96	φ 120/210	φ 120/210	26.6	48	825	555	φ760	210	φ500	15	45	35	390
	1500	260-480																
YOXvIIz750	1000	170-330	1.35-1.5	2-2.3	0.96	φ 130/210	φ 130/210	37.7	68	920	590	φ860	265	φ630	15	50	40	513
	1500	380-760																
YOXvIIz875	750	140-280	1.35-1.5	2-2.3	0.96	φ 140/250	φ 140/250	62.1	112	1032	672	φ992	265	φ630	20	75	40	690
	1000	330-620																

说明：YOXvIIz型为加长后辅腔、输出端带制动轮，使驱动单元结构紧凑，延长工作机起动时间，一般为22-30秒。

此结构特别适用于起动加速度低、高带速、大运量且要求带制动装置的胶带输送机。

Notes: YOXvIIz is a type with longer delay chamber with brake wheel in output side, making the structure closer and enlong the startup time to 22-30s. Thin is special suitable for startup of belt conveyer with low accerlation. High speed,large mass and with brake system.



一流产品 一流服务
First-class products First-class service



HENAN MODERN INDUSTRIAL, CO LIMITED

ADD: NO.8 Linke ROAD, ZHENGZHOU, HENAN PROVINCE. CHINA Postcode: 450000

TEL: + 86-371-88881695 FAX: + 86-371-88881697 WEB: WWW.BRAKE.HK

YOXvs型结构图及主要技术参数：（YOXvs同结构型）
YOXvs Type Structural Drawing and Main Technical Date: (YOXvs the same structura type)

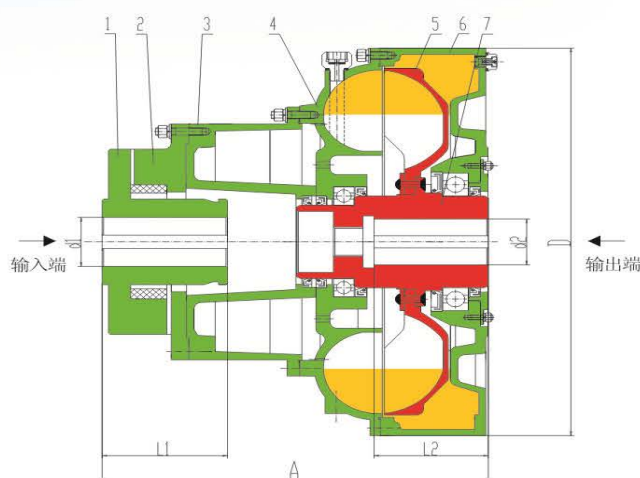

传动形式十二：

- 1.主动节
- 2.从动节
- 3.加长后辅腔
- 4.泵轮
- 5.涡轮
- 6.外侧辅腔
- 7.主轴

Transmission XII:

- 1.Driving Connection
- 2.Driven Connection
- 3.Longer Delay chamber
- 4.Outer Wheel
- 5.Inner Wheel
- 6.Aux.chamber
- 7.Coupling Hub

规格型号 Specification Type	输入转速 Input speed n(r.p.m)	传递功率范围 Ranger of power transmitted N (KW)	过载系数 Overload coeff Tg		效率 Effic ency η	外形尺寸 (mm) Dimensions (mm)		最大输入孔径及长度 Max.Input bore diameter & Length $\frac{d1max}{L1max}$	最大输出孔径及长度 Max.output bore diameter & Length $\frac{d2max}{L2max}$	充油量 q (L) Volume of filling oil		重量 p(kg)
			起动 start	制动 brake		D	A			40% qmin	80% qmax	
YOXvs360	1000	5-10	1.1-1.35	2-2.3	0.96	$\phi 428$	360	$\frac{\phi 60}{110}$	$\frac{\phi 55}{110}$	5.3	8.8	52
	1500	16-30										
YOXvs400	1000	8-18.5	1.1-1.35	2-2.3	0.96	$\phi 472$	390	$\frac{\phi 70}{110/140}$	$\frac{\phi 60}{140}$	7.7	13.5	77
	1500	28-48										
YOXvs450	1000	15-30	1.1-1.35	2-2.3	0.96	$\phi 530$	445	$\frac{\phi 75}{140}$	$\frac{\phi 70}{140}$	11.1	19.5	96
	1500	50-90										
YOXvs500	1000	25-50	1.1-1.35	2-2.3	0.96	$\phi 582$	510	$\frac{\phi 90}{170}$	$\frac{\phi 90}{170}$	15.3	26.8	133
	1500	68-144										
YOXvs560	1000	40-80	1.1-1.35	2-2.3	0.96	$\phi 634$	530	$\frac{\phi 100}{170/210}$	$\frac{\phi 100}{210}$	19.5	34.2	185
	1500	120-270										
YOXvs600	1000	60-115	1.1-1.35	2-2.3	0.96	$\phi 695$	575	$\frac{\phi 100}{170/210}$	$\frac{\phi 115}{210}$	24.9	43.6	220
	1500	200-360										
YOXvs650	1000	90-176	1.1-1.35	2-2.3	0.96	$\phi 760$	650	$\frac{\phi 130}{210}$	$\frac{\phi 130}{210}$	35.6	62.4	260
	1500	260-480										
YOXvs750	1000	170-330	1.1-1.35	2-2.3	0.96	$\phi 860$	680	$\frac{\phi 140}{250}$	$\frac{\phi 150}{250}$	50.5	88.4	406
	1500	380-760										
YOXvs875	750	145-280	1.1-1.35	2-2.3	0.96	$\phi 992$	820	$\frac{\phi 150}{250}$	$\frac{\phi 150}{250}$	83.1	145.6	580
	1000	330-620										
YOXvs1000	600	160-300	1.1-1.35	2-2.3	0.96	$\phi 1138$	845	$\frac{\phi 150}{250}$	$\frac{\phi 150}{250}$	108.5	192.4	780
	750	260-590										
YOXvs1150	600	265-615	1.1-1.35	2-2.3	0.96	$\phi 1312$	885	$\frac{\phi 170}{300}$	$\frac{\phi 170}{300}$	132	220	940
	750	525-1195										
YOXvs1250	500	235-540	1.1-1.35	2-2.3	0.96	$\phi 1420$	960	$\frac{\phi 200}{300}$	$\frac{\phi 200}{300}$	173	280	1120
	600	400-935										
YOXvs1320	750	800-1800	1.1-1.35	2-2.3	0.96	$\phi 1500$	975	$\frac{\phi 210}{310}$	$\frac{\phi 210}{310}$	202	295	1230
	500	315-710										
	600	650-1200	1.1-1.35	2-2.3	0.96	$\phi 1500$	975	$\frac{\phi 210}{310}$	$\frac{\phi 210}{310}$	202	295	1230
	750	1050-2360										

说明：YOXvs型为带加长后辅腔及侧辅腔的结构，其特点是较YOXv型起动时间更长，一般为30-50秒，对要求延长起动时间、提高胶带寿命的胶带输送机特别适用。

Notes: YOXvs makes longer of the delay chamber and Aux chamber-in structure. The features is to longer the time of the starting time, About 30-50s. It's very fixed to improve the time of the belt conveyor and delay the starting time.



一流产品 一流服务
First-class products First-class service



HENAN MODERN INDUSTRIAL, CO LIMITED

ADD: NO.8 Linke ROAD, ZHENGZHOU, HENAN PROVINCE, CHINA Postcode: 450000

TEL: + 86-371-88881695 FAX: + 86-371-88881697 WEB: WWW.BRAKE.HK

YOXVSA型结构图及主要技术参数:

YOXVSA Type Structural Drawing and Main Technical Date:

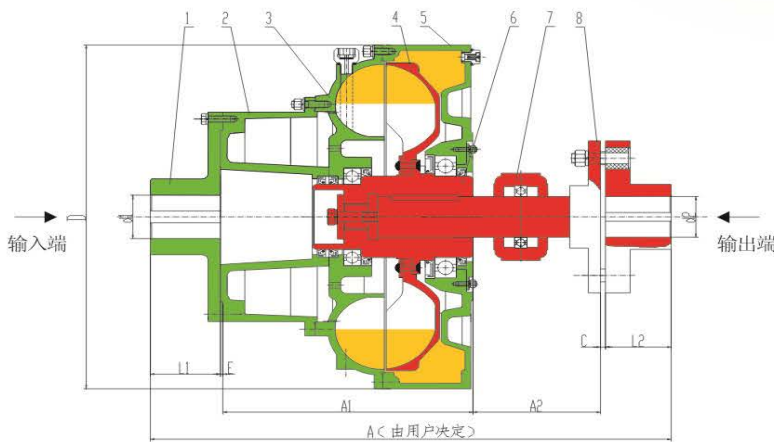

传动形式十三:

- 1.连接盘
- 2.加长后辅腔
- 3.泵轮
- 4.涡轮
- 5.外侧后辅腔
- 6.主轴
- 7.轴承座
- 8.弹性套柱销
联轴器

Transmission XIII:

- 1.Holding Disc
- 2.Longer Delay Chamber
- 3.Pump Wheel
- 4.Turbo Wheel
- 5.Aux. Chamber
- 6.Shaft
- 7.Bear seat
- 8.Shaft coupling with
pin in elastic sleeve

规格型号 Specification Type	输入转速 Input speed n(r.p.m)	传递功率范围 Ranger of power transmitted (KW)	过载系数 Over load coeff Tg		效率 Effic ency	外型尺寸 (mm) Dimensions (mm)					最大输入孔 径及长度 Max.Input bore diameter & Length d1max L1max	弹性套柱销联轴器 Shaft coupling with pin in elastic sleav GB4323-84		充油量 q (L) Volume of filling oil		重量 Weight (kg)	
			起动 start	制动 brake		D	A1	A2	C	E		Type	d,max	l,max	40% qmin		80% qmin
YOXVSA360	1000	5-10	1.1-1.35	2-2.3	0.96	φ428	278	55	8	6	φ55 110	TL5	φ50	112	5.3	8.8	65
	1500	16-30										TL6					
YOXVSA400	1000	8-18.5	1.1-1.35	2-2.3	0.96	φ472	308	65	8	6	φ65 140	TL6	φ65	142	7.7	13.5	96
	1500	28-48										TL7					
YOXVSA450	1000	15-30	1.1-1.35	2-2.3	0.96	φ530	353	65	8	6	φ75 140	TL7	φ75	142	11.1	19.5	120.5
	1500	50-90										TL8					
YOXVSA500	1000	25-50	1.1-1.35	2-2.3	0.96	φ582	391	85 255	10	6	φ95 170	TL8	φ95	172	15.3	26.8	173.5
	1500	68-144										TL10					
YOXVSA560	1000	40-80	1.1-1.35	2-2.3	0.96	φ634	433	85 270	10	6	φ120 210	TL9	φ120	212	19.5	34.2	263
	1500	120-270										TL10					
YOXVSA600	1000	60-115	1.1-1.35	2-2.3	0.96	φ695	467	110 295	12	8	φ120 210	TL10	φ120	212	24.9	43.6	277
	1500	200-360										TL11					
YOXVSA650	1000	90-176	1.1-1.35	2-2.3	0.96	φ760	520	110 295	12	8	φ150 250	TL10	φ150	252	35.6	62.4	326
	1500	260-480										TL11					
YOXVSA750	1000	170-330	1.1-1.35	2-2.3	0.96	φ860	550	125 325	12	8	φ150 250	TL11	φ150	252	50.5	88.4	507
	1500	380-760										TL12					
YOXVSA875	750	140-280	1.1-1.35	2-2.3	0.96	φ992	632	125 325	12	8	φ150 250	TL11	φ150	252	83.1	145.6	729
	1000	330-620										TL12					
YOXVSA1000	600	160-300	1.1-1.35	2-2.3	0.96	φ1138	692	150 350	15	10	φ150 250	TL12	φ150	252	108.5	192.4	980
	750	260-590										TL13					

说明: 此结构的特点为:

- 1、YOXVSA为加长后辅腔、侧辅腔带制动轮结构,特点是起动时间长,一般为30-50秒,对要求延长起动时间,提高胶带寿命的胶带输送机特别适用。
- 2、安装后需拆卸耦合器时,不用移动电机和减速机。只需拆去弹性柱销和连接盘与耦合器的联接螺栓,再将耦合器向输出端移动便可吊出。
- 3、YOXVSA 500~1000轴向长度过长,易引起振动,需带轴承座, A2右下为带轴承座的安装尺寸。

Notes: This form has following festures:

- 1.YOXVSA makes longer of the delay chamber and aux.chamber with brake wheel in output side in structre.feature is to longer the time of the starting time,about30-50s.Its very fixed to improve the belt com veyor and delay the starting time.
- 2.It doesn' t need to move motor and reducer during dismounting couplings,it only needs to remove the flexblb pin and boit which connects the terminal area and couplings,then move couplings output to hang it up.
- 3.The lower dimensions of A2 is for YOXVSA 500~1000 with bearing stand.



一流产品 一流服务

First-class products First-class service



HENAN MODERN INDUSTRIAL, CO LIMITED

ADD: NO.8 Linke ROAD, ZHENGZHOU, HENAN PROVINCE. CHINA Postcode: 450000

TEL: + 86-371-88881695 FAX: + 86-371-88881697 WEB: WWW.BRAKE.HK

YOXVSAZ型结构图及主要技术参数：（YOXysz同结构型）

YOXVSAZ Type Structural Drawing and Main Technical Date:(YOXysz the same structure type)

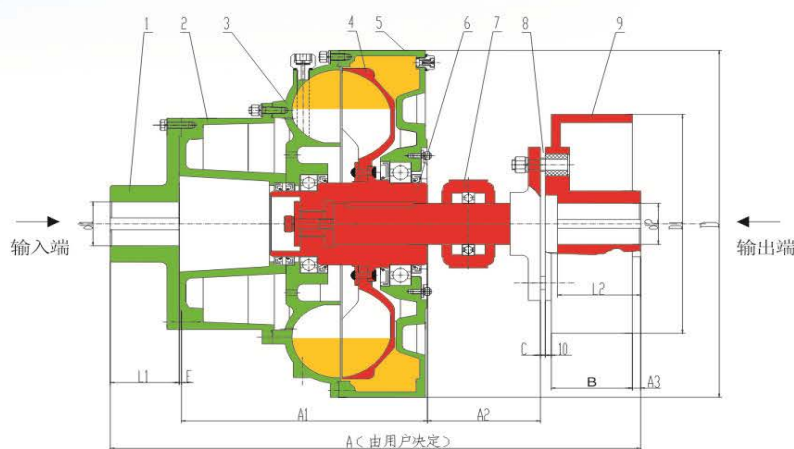

传动形式十四：

- 1.连接盘
- 2.加长后辅腔
- 3.泵轮
- 4.涡轮
- 5.外侧辅腔
- 6.主轴
- 7.弹性套柱销轴器
- 8.制动轮

Transmission XIV:

1. Holding Disc
2. Longer Delay Chamber
3. Pump Wheel
4. Turbo Wheel
5. Aux. Chamber
6. Shaft
7. Shaft coupling with pin in elastit sleeve
8. Brake Wheel

规格型号 Specification Type	输入转速 Input speed n(r.p.m)	传递功率 范围 Ranger of power transmitted N (KW)	过载系数 Overload coeff Tg		效率 Effic η	安装尺寸 (mm) Dimensions (mm)					最大输入孔 直径长度 Max.Input bore diameter & Length d _{max} L _{max}	弹性套柱销联轴器 Shaft coupling with pin in elastic sleav		充油量 (L) Volume of filling oil		重量 Weight (kg)	
			启动 start	制动 brake		D	A ₁	A ₂	C	E		Type	d _{max}	L _{max}	q _{min} (L) 40%		q _{min} (L) 80%
YOXV SA Z 360	1000	5-10	1.1-1.35	2-2.3	0.96	φ428	278	55	8	6	φ55	TL5	φ55	112	3.8	6.8	65
	1500	16-10															
YOXV SA Z 400	1000	8-18.5	1.1-1.35	2-2.3	0.96	φ472	308	65	8	6	φ65	TL6	φ65	142	5.8	10.4	96
	1500	28-48															
YOXV SA Z 450	1000	15-30	1.1-1.35	2-2.3	0.96	φ530	353	65	8	6	φ75	TL7	φ75	142	8.3	15	120
	1500	50-90															
YOXV SA Z 500	1000	25-50	1.1-1.35	2-2.3	0.96	φ582	391	85	10	6	φ95	TL8	φ95	172	11.4	20.6	167
	1500	68-144						255									
YOXV SA Z 560	1000	40-80	1.1-1.35	2-2.3	0.96	φ634	433	85	10	6	φ120	TL9	φ120	212	14.6	26.4	252
	1500	120-270						270									
YOXV SA Z 600	1000	60-115	1.1-1.35	2-2.3	0.96	φ695	467	110	12	8	φ120	TL10	φ120	212	18.6	33.6	302
	1500	200-360						295									
YOXV SA Z 650	1000	90-176	1.1-1.35	2-2.3	0.96	φ760	520	110	12	8	φ150	TL10	φ150	252	26.6	48	505
	1500	260-480						295									
YOXV SA Z 750	1000	170-330	1.1-1.35	2-2.3	0.96	φ860	550	125	12	8	φ150	TL11	φ150	252	37.37	68	510
	1500	380-760						325									
YOXV SA Z 875	750	140-280	1.1-1.35	2-2.3	0.96	φ992	632	125	12	8	φ150	TL11	φ150	252	62.1	112	720
	1000	330-620						325									

说明：此结构的特点为：

- 1、YOXVSAZ为加长后辅腔、侧辅腔带制动轮结构，特点是起动时间长，一般为30-50秒，对要求延长起动时间，提高胶带寿命的胶带输送机特别适用。
- 2、安装后需拆卸偶合器时，不用移动电机和减速机。只需拆去弹性柱销和连接盘与偶合器的联接螺栓，再将偶合器向输出端移动便可吊出。
- 3、YOXVSAZ500~875轴向长度过长，易引起振动，需带轴承座，A2右下为带轴承座的安装尺寸。

Notes: This form has following festures:

1. YOXVSAZ makes longer of the delay chamber and aux. chamber with brake wheel in output side in structre. feature is to longer the time of the starting time, about 30-50s. Its very fixed to improve the belt conveyor and delay the starting time.
2. It doesn't need to move motor and reducer during dismounting couplings, it only needs to remove the flexit pin and bolt which connects the terminai area and couplings, then move couplings output to hang it only needs to remove the flexit pin and bolt which
3. The lower dimensions of A2 is for YOXVSAZ 500~875 with bearing stand.



一流产品 一流服务
First-class products First-class service



HENAN MODERN INDUSTRIAL, CO LIMITED

ADD: NO.8 Linke ROAD, ZHENGZHOU, HENAN PROVINCE, CHINA Postcode: 450000

TEL: + 86-371-88881695 FAX: + 86-371-88881697 WEB: WWW.BRAKE.HK

YOXvsnz型结构图及主要技术参数:

YOXvsnz Type Structural Drawing and Main Technical Date:

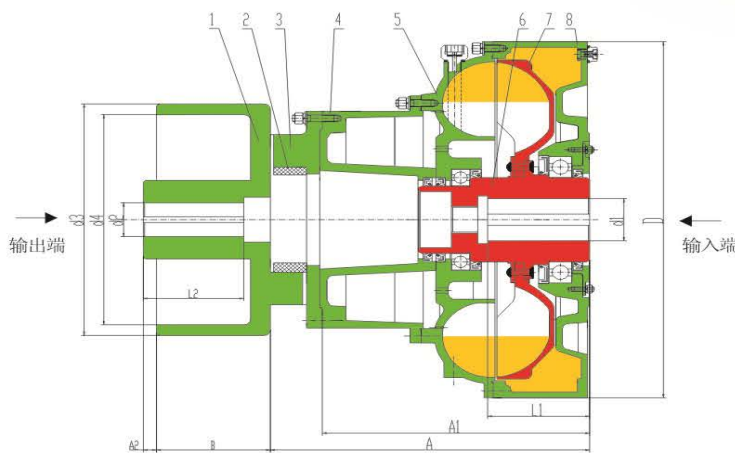

传动形式十五:

- 1.制动轮
- 2.弹性胶块
- 3.从动节
- 4.加长后辅腔
- 5.泵轮
- 6.主轴
- 7.涡轮
- 8.外腔辅腔

Transmission XV:

- 1.Brake wheel
- 2.Elastic block
- 3.Driven connection
- 4.Longer delay chamber
- 5.Pump wheel
- 6.Shaft
- 7.Turbo wheel
- 8.Aux.chamber

规格型号 Specification Type	输入转速 Input speed n(r.p.m)	传递功率 范围 Ranger of power transmitted N (KW)	过载系数 Overload coeff Tg		效率 Effic iency η	外型尺寸 (mm) Dimensions (mm)				最大输入孔 径及长度 Max.Input bore diameter & Length d,max/L,max	最大输出孔 径及长度 Max.output bore diameter & Length d,max/L,max	制动轮外形尺寸 Dimensions of brake wheel			充油量 (L) Volume of filling oil		重量 Weight (kg)
			起动 start	制动 brake		D	A	A1	A2			d ₃	d ₄	B	qmin (L) 40%	qmax (L) 80%	
YOXvsnz360	1000	5-10	1.5-1.8	2-2.5	0.96	φ428	331	278	10	φ55 110	φ60 110	按用户提供尺寸加工	5.3	8.8	50		
	1500	16-30															
YOXvsnz400	1000	8-18.5	1.5-1.8	2-2.5	0.96	φ472	368	308	10	φ60 120	φ70 140		7.7	13.5	74		
	1500	28-48															
YOXvsnz450	1000	15-30	1.5-1.8	2-2.5	0.96	φ530	419	353	10	φ70 140	φ75 140		11.1	19.5	93.5		
	1500	50-90															
YOXvsnz500	1000	25-50	1.5-1.8	2-2.5	0.96	φ582	462	391	15	φ90 170	φ90 170		15.3	26.8	134		
	1500	68-144															
YOXvsnz560	1000	40-80	1.5-1.8	2-2.5	0.96	φ634	508	433	15	φ100 210	φ100 210		19.5	34.2	159		
	1500	120-270															
YOXvsnz600	1000	60-115	1.5-1.8	2-2.5	0.96	φ695	550	467	15	φ100 210	φ100 210	24.9	43.6	200			
	1500	200-360															
YOXvsnz650	1000	90-176	1.5-1.8	2-2.5	0.96	φ760	605	520	15	φ130 210	φ130 210	35.6	62.4	257			
	1500	260-480															
YOXvsnz750	1000	170-330	1.5-1.8	2-2.5	0.96	φ860	648	550	20	φ150 250	φ140 250	50.5	88.4	425			
	1500	380-760															
YOXvsnz875	750	140-280	1.5-1.8	2-2.5	0.96	φ992	738	632	20	φ150 250	φ150 250	83.1	146	596			
	1000	330-620															

说明: 此结构的特点为:

- 1、YOXvsnz为内轮驱动，加长后辅腔、外侧辅腔、输出端带制动轮的结构。
- 2、适用于要求延长起动时间，一般为30-50S带制动轮的驱动单元，其结构简单、紧凑。

Notes: This form has following festures:

- 1.YOXvsnz is inner-wheel drive type with the longer deaiy chamber and Aux.Chamber and brake wheel in output side.
- 2.It is suitable for longer the time of the starting time, about 30-50S and driven unit with brake in structure which makes it simple and well-knit.

一流产品 一流服务

First-class products First-class service



HENAN MODERN INDUSTRIAL, CO LIMITED

ADD: NO.8 Linke ROAD, ZHENGZHOU, HENAN PROVINCE, CHINA Postcode: 450000

TEL: + 86-371-88881695 FAX: + 86-371-88881697 WEB: WWW.BRAKE.HK

YOXvsII z型结构图及主要技术参数:

YOXvsII Z Type Structural Drawing and Main Technical Date:

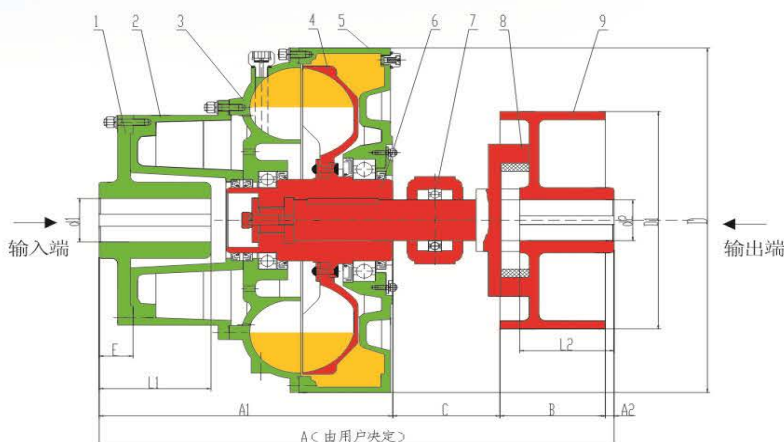

传动形式十六:

- 1.连接盘
- 2.加长后辅腔
- 3.泵轮
- 4.涡轮
- 5.外侧辅腔
- 6.主轴
- 7.轴承座
- 8.连接轴
- 9.制动轮

Transmission XVI:

1. Holding Disc
2. Longer Delay Chamber
3. Pump Wheel
4. Turbo Wheel
5. Aux. Chamber
6. Shaft
7. Bearing seat
8. Connecting shaft
9. Brake Wheel

规格型号 Specification Type	输入转速 Input speed n(r.p.m)	传递功率 Ranger of power transmitted N (KW)	过载系数 Overload coeff Tg		效率 Effic iency η	最大输入孔径及长度 Max.Input bore diameter & Length d,max/L,max	最大输出孔径及长度 Max.output bore diameter & Length d,max/L,max	充油量 (L) Volume of filling oil		外型尺寸 Dimensions (mm)							重量 Weight (kg)	
			启动 start	制动 brake				40% qmin	80% qmax	A	A ₁	D	B	D ₁	A ₂	C		E
YOXvsII z400	1000	8-18.5	1.1-1.35	2-2.3	0.96	φ65/140	φ65/140	7.7	13.5	556	358	φ472	150	φ315	10	38	50	120
	1500	28-48																
YOXvsII z450	1000	15-30	1.1-1.35	2-2.3	0.96	φ75/140	φ75/140	11.1	19.5	581	383	φ530	150	φ315	10	38	30	135
	1500	50-90																
YOXvsII z500	1000	25-50	1.1-1.35	2-2.3	0.96	φ90/170	φ90/170	15.3	26.8	672	431	φ582	190	φ400	10	41	40	183
	1500	68-144																
YOXvsII z560	1000	40-80	1.1-1.35	2-2.3	0.96	φ110/210	φ110/210	19.5	34.2	748	503	φ634	190	φ400	10	45	70	240
	1500	120-270																
YOXvsII z600	1000	60-115	1.1-1.35	2-2.3	0.96	φ110/210	φ110/210	24.9	43.6	787	517	φ695	210	φ500	15	45	50	370
	1500	200-360																
YOXvsII z650	1000	90-176	1.1-1.35	2-2.3	0.96	φ120/210	φ120/210	35.6	62.4	825	555	φ760	210	φ500	15	45	35	415
	1500	260-480																
YOXvsII z750	1000	170-330	1.1-1.35	2-2.3	0.96	φ130/210	φ130/210	50.5	88.4	920	590	φ860	265	φ630	15	50	40	544
	1500	380-760																
YOXvsII z875	750	140-280	1.1-1.35	2-2.3	0.96	φ140/250	φ140/250	83.1	145.6	1032	672	φ992	265	φ630	20	75	40	740
	1000	330-620																

说明: YOXvsII z型为加长后辅腔、加大侧辅腔带制动轮结构,是起动能最好的一种结构型式,能使工作机的起动时间更长,一般为30-50秒。此为带制动轮偶合器结构型式,其特点为:

- 1、外轮驱动,结构紧凑。
- 2、适用于对延长起动时间的胶带机,带制动机构的驱动单元。
- 3、YOXvsII z 500~875轴向长度过长,易引起振动,需带轴承座, A、A₁右下为带轴承座的安装尺寸。

Notes: Type YOXvsII z is a structure with longer delay chamber & bigger Aux chamber, its startup is the best, which the time can be 30-50s. It is the type of brake system with the following features:

1. Outer wheel drive with compact structure.
2. Suitable for belt conveyor with longer start up time & brak system.
3. The lower dimensions of A、A₁、 is for YOXvsII z 500~875 with bearing stand.



一流产品 一流服务
First-class products First-class service



HENAN MODERN INDUSTRIAL, CO LIMITED

ADD: NO.8 Linke ROAD, ZHENGZHOU, HENAN PROVINCE, CHINA Postcode: 450000

TEL: + 86-371-88881695 FAX: + 86-371-88881697 WEB: WWW.BRAKE.HK

限矩水介质液力耦合器



一、结构特点:

1. 耦合器内轴承采用了双重密封结构, 不与水接触, 有独立润滑措施, 因而轴承的使用寿命较长。
2. 工作腔内, 凡是与水接触的钢铁零部件都经过特殊处理采用不锈钢材料, 大大提高其防锈能力。
3. 配置了压力防爆结构的易爆塞。
4. 我公司水介质系列耦合器已取得安标中心颁发的安全标志证书。

二、使用特点:

1. 提高鼠笼式电动机的启动能力, 可在重载下进行启动。
2. 缩短电动机启动时间, 减小启动中的平均电流。
3. 减少启动的冲击和振动, 防止动力过载, 保护电动机工作机不会因过载而损坏。
4. 在多机驱动中, 能使功率平衡, 减少电网的冲击电流。
5. 结构简单, 运行可靠, 无机械磨损, 使用寿命长。无需特殊维护。
6. 可用清水(或难燃液)做工作介质, 使耦合器适用于矿井下和食品、纺织、化工等设备上, 杜绝了耦合器因用油作工作介质时因过载喷油所引起的火灾、爆炸事故和污染。
7. 因用水作工作介质, 节约了用油作介质时的运行费用, 也节约了能源。

三、用途:

刮板输送机, 胶带输送机, 链式输送机, 螺旋输送机, 挖掘机, 各种提升机, 刨煤机, 球磨机, 破碎机, 各式起重机, 斗轮挖掘机, 斗轮堆取料机, 离心机, 清洗机, 制革转鼓机, 游艺机, 搅拌机, 拉丝机, 炼胶机, 注塑机, 挤压机, 预加水成球机, 锅炉碎渣机, 水泵, 风机。

四、YOXD型结构图及主要技术参数:

说明: 1、耦合器内充水应选用“天然水”, (如矿井地下水, 自来水)水中不能夹带泥沙, 杂质, 如环境不允许用水(如冬季环境温度低于0℃时)可用M—10乳化液, 操作规定按说明书要求。

2、输入、输出端孔径大小, 长度及键槽尺寸均按用户要求加工。

3、本公司可按用户要求生产任何形式的各规格耦合器。

YOXD水介质系列限矩型液力耦合器功率图谱:
Power Diagram of YOXD Water Couplings

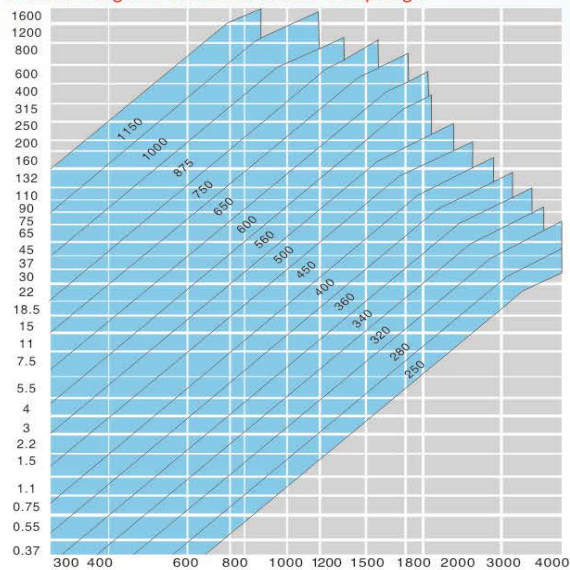

输入转速 Input speed (r/min)

1. Features:

- 1.1 Double seals inside and separate lubricating system for long service life of Bearings.
- 1.2 All parts made of iron & steel and metal-to-water contact will be specially treated, or will be made of stainless steel for better antirust ability.
- 1.3 A fusible plug for anti-explosion is equipped.
- 1.4 Safety Certificates issued by the Coal Ministry for all sizes of water couplings Are available.

2. Advantages:

- 2.1 Increasing the startup ability of squire-motor and enabling the startup heav load.
- 2.2 Shortening the startup time of motor and reducing the average current.
- 2.3 Reducing the shock and vibration during startup and preventing overload.
- 2.4 Power balance to reduce the impact current in multi-motor drives.
- 2.5 Simple construction and reliable operation. No mechanical wear and long service life. Free of special maintenance.
- 2.6 Water as working fluid, enabling the couplings to be used underground or equipped with machines in foodstuff plant, spinnery or chemical plant. Accidents of fire, explosion and pollution caused by overheated oil of couplings are avoided.
- 2.7 Cost is reduced and energy is saved for water as working

3. Application:

AFC, Belt Conveyor, Chain Conveyor, Spiral Conveyor, Excavator, Bucket Ex-cavator, Bucket Conveyor, Ball Crusher, Crusher, Coal Planner, Tower Crane, Gantry Crane, Bridge Crane, Centrifuge, Washer, Leather Drum, Entertaining Machine, Mixer, Wire-drawing Machine, Rubber smelting Machine, Plastic Feeder, Extruding Machine, Boiler Roler. Etc.

4. Construction & main technical data of YOXD Note:

- 4.1 The water filled in couplings shall be "natural water" (such as groundwater, tap water). Water is not allowed to combine with sand and impurity. If the environment is not allowed (such as the temperature is lower than 0℃ in winter), the M-10 emulsion can be alternate.
- 4.2 The dimension of input and output bore, length and key is machined according to user's requirement.
- 4.3 All sizes of couplings specified by user can be provided by our company.



一流产品 一流服务
First-class products First-class service



HENAN MODERN INDUSTRIAL, CO LIMITED

ADD: NO.8 Linke ROAD, ZHENGZHOU, HENAN PROVINCE. CHINA Postcode: 450000

TEL: + 86-371-88881695 FAX: + 86-371-88881697 WEB: WWW.BRAKE.HK

YOXD型结构图及主要技术参数：(YOXs.YOXsj 同结构型)
YOXD Type Structural Drawing and Main Technical Date:(YOXs.YOXsj The same structure type)



YOXD Tfas TVAs (平键)

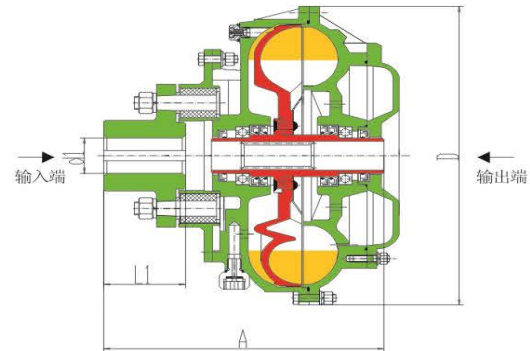

YOXD (花键)

规格型号 Specification type	输入转速 Input speed (r/min)	传递功率范围 Range of Power Transmitted (KW)	过载系数 (Tg) Over load coeff		效率 Effic lency	外型尺寸 Dimensions (mm)		最大输入孔径及长度 Max input bore Diameter Length d1max/L1max	最大输出孔径及长度 Max output bore diameter & Length d2max/L2max	充油量 (L) Volume of Filling oil		重量 weight (KG)	备注	
			起动 stat	制动 brake		D	A			40% qmin	80% qmax			
YOXD360B	1000 1500	6-12 17-37	1.5-1.8	2-2.5	0.96	φ415	360	φ 60/140	φ 50/110	3.4	6.8	45		
YOXD400B	1000 1500	10-22 30-56	1.5-1.8	2-2.5	0.96	φ465	355	φ 70/140	φ 70/140	5.2	10.8	65		
YOXD420B	1000 1500	8-16 22-45	1.5-1.8	2-2.5	0.96	φ490	380	φ 70/140	φ 50/110	6	10	69		
YOXD450B	1000 1500	17-35 55-110	1.5-1.8	2-2.5	0.96	φ520	438	φ 75/140	φ 80/140	7	14	85		
YOXD450S	1000 1500	17-35 55-110	1.5-1.8	2-2.5	0.96	φ520	508	φ 80/170	φ 80/170	7	14	123	YOXD450III	
YOXD487	1000 1500	23-55 60-150	1.5-1.8	2-2.5	0.96	φ556	450	φ 75/140	φ 100/140	9.2	18.4	98		
YOXD500A	1000 1500	27-58 70-170	1.5-1.8	2-2.5	0.96	φ556	474	φ 90/170	φ 100/170	10.2	20.4	150		
YOXD500B	1000 1500	27-58 70-170	1.5-1.8	2-2.5	0.96	φ582	435/480	φ 100/170	φ 100/170	10.2	20.4	152		
YOXD560	1000 1500	45-100 140-315	1.5-1.8	2-2.5	0.96	φ634	474/520	φ 100/210	φ 100/180	14	28	160		
YOXD600	1000 1500	70-135 230-418	1.5-1.8	2-2.5	0.96	φ695	540	φ 110/210	φ 100/180	17	34	195		
YOXD650	1000 1500	100-205 300-560	1.5-1.8	2-2.5	0.96	φ760	600	φ 120/210	φ 100/180	24	48	246		
YOXD360	1000 1500	6-12 17-37	1.5-1.8	2-2.5	0.96	φ415	365/380	φ 60/110	渐开线花键 INT16Z × 2.5M × 30P	3.4	6.8	50	定心孔 φ50 × 55	
YOXD360A	1000 1500	10-22 30-56	1.5-1.8	2-2.5	0.96	φ415	229			3.4	6.8	40		
YOXD400	1000 1500	10-22 30-56	1.5-1.8	2-2.5	0.96	φ465	380/394	φ 70/110		5.2	10.4	70		定心孔 φ45 × 96
YOXD420	1000 1500	8-16 22-45	1.5-1.8	2-2.5	0.96	φ490	380	φ 70/110		6	10	79		定心孔 φ50 × 55
YOXD420A	1000 1500	8-16 22-45	1.5-1.8	2-2.5	0.96	φ490	323		6	10	55			
YOXD450	1000 1500	17-35 55-110	1.5-1.8	2-2.5	0.96	φ520	440	φ 95/140	渐开线花键 INT16Z × 3.5M × 30P	7	14	90	定心孔 φ65 × 120	
YOXD500	1000 1500	27-58 70-170	1.5-1.8	2-2.5	0.96	φ570	478	φ 100/170		10.2	20.4	105	定心孔 φ65 × 120	
YOXD650	1000 1500	100-205 300-700	1.5-1.8	2-2.5	0.97	φ720	576/719	φ 120/210	渐开线花键 INT21Z × 5M × 30P	24	48	288	定心孔 φ 115 × 50 定心孔 φ 115 × 75	

说明: 1、此类液力耦合器为水介质, 除具有YOX, TVA型的特点外, 它适用于要求防燃、易爆、防油污染的工作环境, 常用于煤矿井下。

2、当L₁、L₂超过表列L₁max、L₂max时可相应增加A。

Notes: 1. In addition to features of type YOX, TVA, this type of fluid couplings is flame-proof and explosion-proof type, especially designed for fire of explosion hazard, such as coal mine.

2. when H₁ and H₂ are greater than listed H₁ max and H₂ max, L should be increased correspondingly.

一流产品 一流服务
First-class products First-class service



HENAN MODERN INDUSTRIAL, CO LIMITED

ADD: NO.8 Linke ROAD, ZHENGZHOU, HENAN PROVINCE, CHINA Postcode: 450000

TEL: + 86-371-88881695 FAX: + 86-371-88881697 WEB: WWW.BRAKE.HK

YOXDA型结构图及主要技术参数：（YOXSjA同结构型）
YOXDA Type Structural Drawing and Main Technical Date: (YOXSjA the same sturcture type)

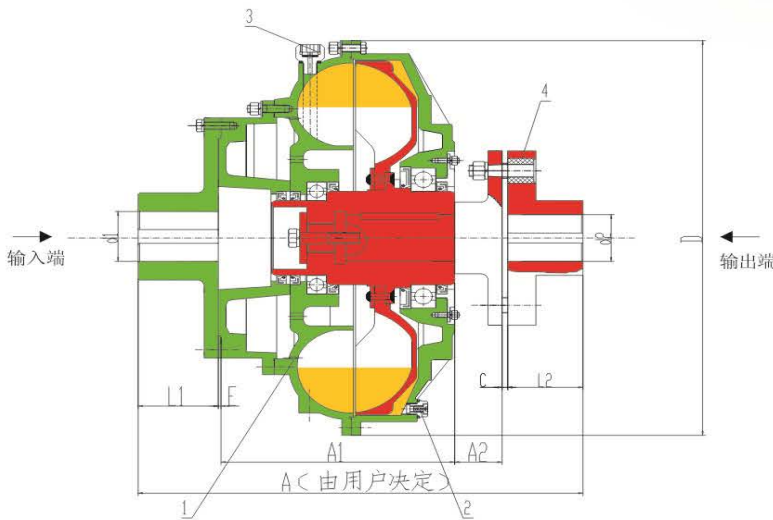

传动形式二：

单腔型外轮驱动带弹性套柱销联轴器

- 1.液力偶合器
- 2.易熔塞
- 3.易爆塞

4.弹性套柱销联轴器

这种传动形式，装拆方便

Transmission from II :

Single cavity outer-wheel drint type with shaft coupling pin in elastic sleeve.

- 1.Constant filling fluid coupling
- 2.Fusible plug
- 3.Explosion protection plug
- 4.Shaft coupling with pin in elastil Sleeve

This form is easy to be assembled and disassembled

规格型号 Specifacaton type	输入转速 Input speed n(r.p.m)	传递功率 范围 Ranger of power transmitted N (KW)	过载系数 Over load coeff Tg		效率 Effic ency η	外型尺寸 Dimensions (mm)					最大输入孔 径及长度 Max.Input bore diameter & Length d,max/l,max	弹性套柱销联轴器 Shaft coupling with pin in elastic sleeve GB4323-84			充液量 (L) Volume of filling oil		重量 Weight 不含制动 轮重量 (kg)
			起动 start	制动 brake		D	A ₁	A ₂	C	E		型号 Type	d ₂ max	L ₂	40% qmin	80% qmax	
YOXDA400	1000	10-22	1.5-1.8	2-2.5	0.96	φ 472	261	65	8	6	φ 65/140	TL6	φ 65	142	5.2	10.4	79
	1500	30-56										TL7					
YOXDA450	1000	17-35	1.5-1.5	2-2.5	0.96	φ 530	311	65	8	6	φ 75/140	TL7	φ 75	142	7.5	15	97
	1500	55-110										TL8					
YOXDA500	1000	27-58	1.5-1.8	2-2.5	0.96	φ 582 φ 558	320	85	10	6	φ 95/170	TL8	φ 95	172	10.3	20.5	130
	1500	70-170										TL10					
YOXDA560	1000	45-100	1.5-1.8	2-2.5	0.96	φ 640	367	85	10	6	φ 110/210	TL10	φ 110	212	14	28	185
	1500	140-315										TL11					
YOXDA600	1000	70-135	1.5-1.8	2-2.5	0.96	φ 695	423	110	12	8	φ 120/210	TL11	φ 120	212	17	34	225
	1500	230-418										TL12					
YOXDA650	1000	100-205	1.5-1.8	2-2.5	0.96	φ 760	452	110	12	8	φ 140/250	TL11	φ 140	252	24	48	279
	1500	300-560										TL12					
YOXDA750	1000	195-385	1.5-1.8	2-2.5	0.96	φ 860	496	125	12	8	φ 150/250	TL10	φ 150	252	34	68	425
	1500	550-885										TL12					
YOXDA875	750	168-325	1.5-1.8	2-2.5	0.96	φ 992	546	125	12	8	φ 150/250	TL11	φ 150	252	56	112	600
	1000	380-720										TL12					
YOXDA1000	600	185-350	1.5-1.8	2-2.5	0.96	φ 1138	615	150	15	10	φ 160/300	TL12	φ 160	302	74	148	786
	750	260-690										TL13					
YOXDA1150	600	300-715	1.5-1.8	2-2.5	0.96	φ 1312	709	150	15	10	φ 170/300	TL12	φ 170	302	85	170	978
	750	610-1390										TL13					

说明：此结构特点为：安装后需拆卸耦合器时，不用移动电机和减速机，只需拆去弹性柱销和连接盘与耦合器的联接螺栓，再将耦合器向输出端移动便可吊出。

Notes: This form has following features: It doesn't need to move motor and reducer during dis mounting couplings. It only needs to remove the flexible pin and bolt which connects the terminal area and couplings, then move coupling towards output to hang it up.



一流产品 一流服务

First-class products First-class service



HENAN MODERN INDUSTRIAL, CO LIMITED

ADD: NO.8 Linke ROAD, ZHENGZHOU, HENAN PROVINCE. CHINA Postcode: 450000

TEL: + 86-371-88881695 FAX: + 86-371-88881697 WEB: WWW.BRAKE.HK

YOXDAZ型结构图及主要技术参数：（YOXSjAZ同结构型）

YOXDAZ Type Structural Drawing and Main Technical Date:(YOXSjAZ the same sturcture type)

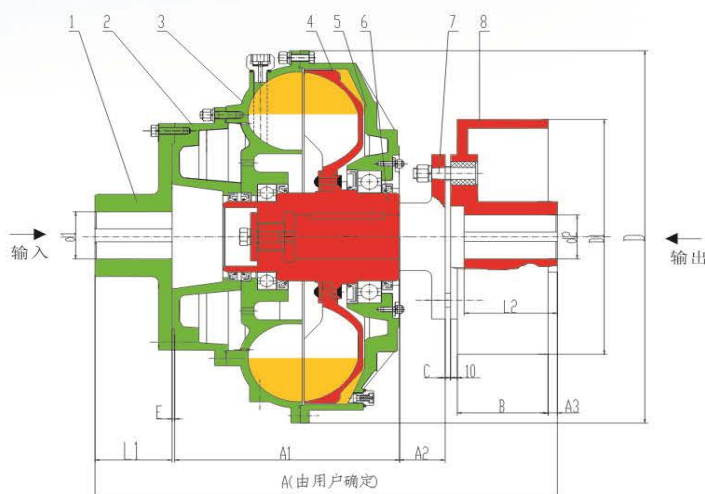

传动形式三：

单腔型外轮驱动带弹性套柱销联轴器

- 1.连接盘
- 2.液力偶合器
- 3.易熔塞
- 4.易爆塞
- 5.半联轴节
- 6.制动轮

这种传动形式，装拆方便

Transmission III：

Single cavity outer-wheel drive type with in shaft coupling pin in elastic sleeve.

- 1.Holding disc
- 2.Water couplings
- 3.Fusible plug
- 4.Explositivn protection plug
- 5.Half shaft connection
- 6.Brake wheel

This form is easy for mounting and dismounting

规格型号 Specificaton Type	输入转速 Input speed n(r.p.m)	传递功率范围 Ranger of power transmitted N (KW)	过载系数 Overloadcoeff Tg		效率 Effic iency η	外型尺寸 Dimensions (mm)				弹性套柱销联轴器 Shaft coupling with pin in elastic sleeve GB4323-84			充液量 (L) Volume of filling oil		重量 Weight 不含制动 轮重量 kg
			起动 start	制动 brake		D	A ₁	E	A ₃	型号 Type	C	A ₂	40% qmin	80% qmax	
YOXDAZ400	1000	10-22	1.5-1.8	2-2.5	0.96	φ 472	261	6	10	TL6	8	65	5.2	10.4	79
	1500	30-56								TL7					
YOXDAZ450	1000	17-35	1.5-1.5	2-2.5	0.96	φ 530	311	6	10	TL7	8	65	7.5	15	97
	1500	55-110								TL8					
YOXDAZ500	1000	27-58	1.5-1.8	2-2.5	0.96	φ582 φ558	320	6	10	TL8	10	85	10.3	20.5	130
	1500	70-170								TL10					
YOXDAZ560	1000	45-100	1.5-1.8	2-2.5	0.96	φ 640	367	6	10	TL9	10	85	14	28	185
	1500	140-315								TL10					
YOXDAZ600	1000	70-135	1.5-1.8	2-2.5	0.96	φ 695	423	8	15	TL10	12	110	17	34	225
	1500	230-418								TL11					
YOXDAZ650	1000	100-205	1.5-1.8	2-2.5	0.96	φ 760	452	8	15	TL10	12	110	24	48	279
	1500	300-560								TL11					
YOXDAZ750	1000	195-385	1.5-1.8	2-2.5	0.96	φ 860	496	8	20	TL11	12	125	34	68	425
	1500	550-885								TL12					
YOXDAZ875	750	168-325	1.5-1.8	2-2.5	0.96	φ 992	546	8	20	TL11	12	120	56	112	600
	1000	380-720								TL12					
YOXDAZ1000	600	185-350	1.5-1.8	2-2.5	0.96	φ1138	615	10	25	TL12	15	150	74	148	786
	750	260-690								TL13					
YOXDAZ1150	600	300-715	1.5-1.8	2-2.5	0.96	φ1312	709	10	25	TL12	15	150	85	170	978
	750	610-1390								TL13					

说明：此结构为A型带制动轮耦合器型式，其特点为：1、安装后需拆卸耦合器时，不用移动电机和减速机，只需拆去弹性柱销和连接盘（1）与耦合器的联接螺栓，再将耦合器向制动轮端移动便可吊出。2、更换弹性胶块和耦合器十分方便。

Notes: This form is the A type in structures with brake wheel. It has the following features:

1. It doesn't need to move motor and reducer during dismounting couplings. It only needs to remove the flexible pin and bolt which connects. The terminal area(1) and couplings. Then move couplings towards brake wheel to hang it up.
2. It is very convenient for replacing elastic block and couplings.



一流产品 一流服务

First-class products First-class service



HENAN MODERN INDUSTRIAL, CO LIMITED

ADD: NO.8Linke ROAD, ZHENGZHOU, HENAN PROVINCE. CHINA Postcode: 450000

TEL: + 86-371-88881695 FAX: + 86-371-88881697 WEB: WWW.BRAKE.HK

YOXD II z型结构图及主要技术参数: (YOXSj II z同结构型)

YOXD II Z Type Structural Drawing and Main Technical Date: (YOXSj II z The same structure type)

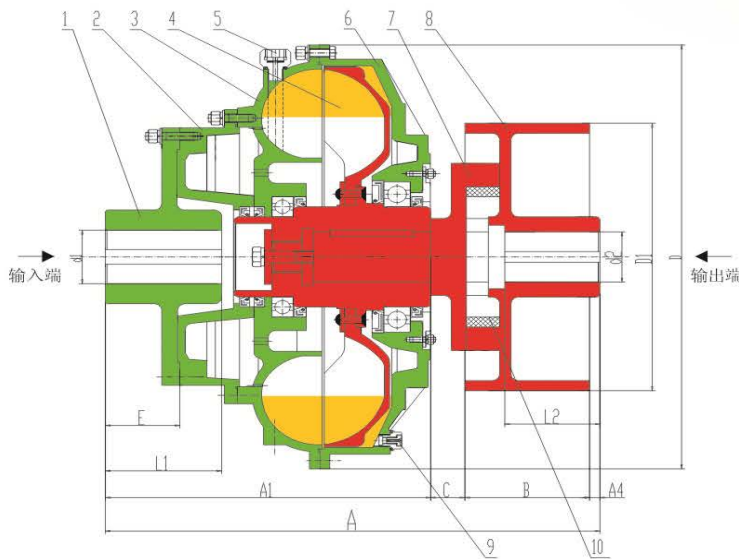

传动形式四:

- 1.连接盘
- 2.后辅腔
- 3.泵轮
- 4.涡轮
- 5.易爆塞
- 6.外壳
- 7.连接轴
- 8.制动轮
- 9.易爆塞
- 10.弹性块

Transmission form IV:

- 1.Holding disc
- 2.Delay chamber
- 3.Outer wheel
- 4.Inner wheel
- 5.Explosion protection plug
- 6.Shell
- 7.Connection shaft
- 8.Brake wheel
- 9.Fusible plug
- 10.Flexible element

规格型号 Specification type	输入转速 Input speed n(r.p.m)	传递功率 范围 Ranger of power transmitted N (KW)	过载系数 Over loadc oeff Tg		效率 Effic iency η	最大输入孔 径及长度 Max.Input bore diameter & Length d-max/l-max	最大输出孔 径及长度 Max.output bore diameter & Length d-max/l2-max	充液量 (L) Volume of filling oil		外型尺寸 Dimensions (mm)							重量 Weight (kg)	
			启动 start	制动 brake				40% qmin	80% qmax	A	A ₁	D	B	D ₁	A ₂	C		E
YOXD II z400	1000	10-22	1.5-1.8	2.0-2.5	0.96	φ 65/140	φ 65/140	5.2	10.4	560	362	φ472	150	φ315	10	38	101	116
	1500	30-56																
YOXD II z450	1000	17-35	1.5-1.8	2.0-2.5	0.96	φ 75/140	φ 75/140	7.5	15	598	400	φ530	150	φ315	10	38	90	131
	1500	55-110																
YOXD II z500	1000	27-58	1.5-1.8	2.0-2.5	0.96	φ 90/170	φ 90/170	10.3	20.6	685	444	φ582 φ558	190	φ400	10	41	124	158
	1500	70-170																
YOXD II z560	1000	45-100	1.5-1.8	2.0-2.5	0.96	φ 100/210	φ100/210	14	28	756	511	φ640	190	φ400	10	45	144	210
	1500	140-315																
YOXD II z600	1000	70-135	1.5-1.8	2.0-2.5	0.96	φ 110/210	φ110/210	17	34	835	565	φ695	210	φ500	15	45	142	265
	1500	230-418																
YOXD II z650	1000	100-205	1.5-1.8	2.0-2.5	0.96	φ 120/210	φ120/210	24	48	855	586	φ760	210	φ500	15	45	134	392
	1500	300-560																
YOXD II z750	1000	195-385	1.5-1.8	2.0-2.5	0.96	φ 130/210	φ130/210	34	68	1001	671	φ860	265	φ630	15	50	175	495
	1500	550-885																
YOXD II z875	750	168-325	1.5-1.8	2.0-2.5	0.96	φ 140/250	φ140/250	56	112	1073	711	φ992	265	φ630	20	75	165	660
	1500	380-720																

说明: 此结构为外轮驱动带制动轮单元, 结构简单, 紧凑。

Notes: This is outer wheel drive type with brake wheel which is simple and tight.



一流产品 一流服务

First-class products First-class service



HENAN MODERN INDUSTRIAL, CO LIMITED

ADD: NO.8 Linke ROAD, ZHENGZHOU, HENAN PROVINCE, CHINA Postcode: 450000

TEL: + 86-371-88881695 FAX: + 86-371-88881697 WEB: WWW.BRAKE.HK

YOXD_V型结构图及主要技术参数：（YOXS_{JV}同结构型）

YOXD_V Type Structural Drawing and Main Technical Date:(YOXS_{JV} the same sturcture type)

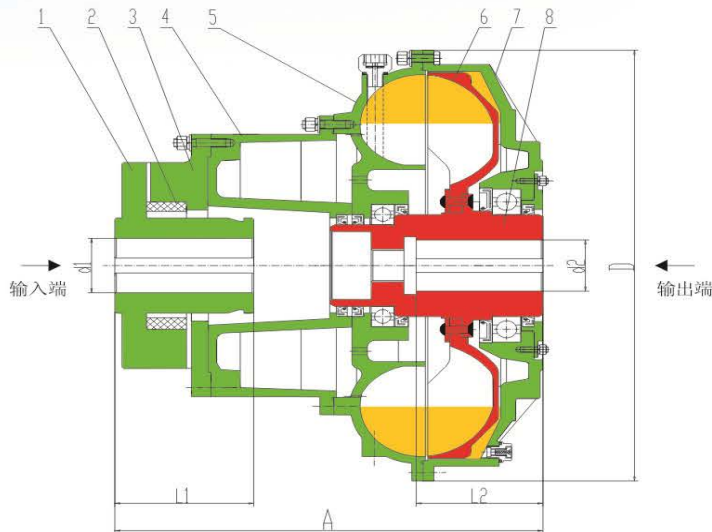

传动形式五:

- 1.主动节
- 2.弹性胶块
- 3.从动节
- 4.后辅腔
- 5.泵轮
- 6.涡轮
- 7.外壳
- 8.主轴

Transmission V:

- 1.Driving connection
- 2.Flexible element
- 3.Driven connection
- 4.Delay chamber
- 5.Outer wheel
- 6.Inner wheel
- 7.Shell
- 8.Hub

规格型号 Specifacaton type	输入转速 Input speed n(r.p.m)	传递功率 范围 Ranger of power transmitted N (KW)	过载系数 Overloadcoeff Tg		效率 Effic iency η	外型尺寸 Dimensions (mm)		最大输入孔 径及长度 Max.Input bore diameter & Length d1max L1max	最大输出孔 径及长度 Max.output bore diameter & Length d2max L2max	充液量 q (L) Volume of filling oil		重量 Weight (kg)
			启动 start	制动 brake		D	A			40% min	80% max	
YOXD _V 400	1000	10-22	1.35-1.5	2-2.3	0.96	φ 472	395	φ 70/140	φ 70/140	5.8	10.4	72
	1500	30-56										
YOXD _V 450	1000	17-35	1.35-1.5	2-2.3	0.96	φ 530	455	φ 75/140	φ 75/140	8.3	15	89
	1500	55-110										
YOXD _V 500	1000	27-58	1.35-1.5	2-2.3	0.96	φ582 φ558	474	φ 90/170	φ 90/170	11.4	20.6	116
	1500	70-170										
YOXD _V 560	1000	45-100	1.35-1.5	2-2.3	0.96	φ 640	530	φ 100/210	φ 100/210	14.6	26.4	165
	1500	140-315										
YOXD _V 600	1000	70-135	1.35-1.5	2-2.3	0.96	φ 695	615	φ 110/210	φ 110/210	18.6	33.6	203
	1500	230-418										
YOXD _V 650	1000	100-205	1.35-1.5	2-2.3	0.96	φ 760	653	φ 120/210	φ 120/210	26.6	48	243
	1500	300-560										
YOXD _V 750	1000	195-385	1.35-1.5	2-2.3	0.96	φ 860	724	φ 130/210	φ 130/210	37.7	68	379
	1500	550-885										
YOXD _V 875	750	168-325	1.35-1.5	2-2.3	0.96	φ 992	800	φ 140/250	φ 140/250	62.1	112	535
	1000	380-720										
YOXD _V 1000	600	185-350	1.35-1.5	2-2.3	0.96	φ1138	890	φ 150/250	φ 150/250	82.5	148	715
	750	260-690										
YOXD _V 1150	600	300-715	1.35-1.5	2-2.3	0.96	φ1312	1010	φ 170/300	φ 170/300	95	170	886
	750	610-1390										

说明: YOXD_V型为加长后辅腔结构,其特点是较YOX型延长了起动时间,一般为22-30秒,对要求降低起动力矩、延长起动时间提高胶带使用寿命的胶带输送机,特别适用。

Notes: YOXD_V makes longer of the delay chamber in structure.The features is to longer the starting time,About 22-30/s.It's very fixed to improve the time of the belt comveyor, delay the starting time.



一流产品 一流服务
First-class products First-class service



HENAN MODERN INDUSTRIAL, CO LIMITED

ADD: NO.8 Linke ROAD, ZHENGZHOU, HENAN PROVINCE, CHINA Postcode: 450000

TEL: + 86-371-88881695 FAX: + 86-371-88881697 WEB: WWW.BRAKE.HK

YOXDV II z型结构图及主要技术参数：(YOXSjv II z同结构型)
YOXDV II Z Type Structural Drawing and Main Technical Date:(YOXSjv II z the same structure type)

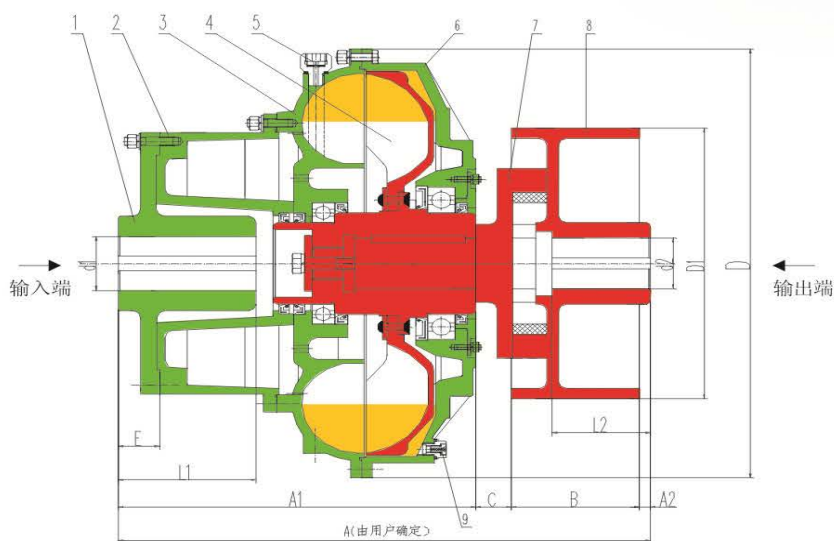

传动形式六：

- 1.连接盘
- 2.后辅腔
- 3.泵轮
- 4.涡轮
- 5.易爆塞
- 6.外壳
- 7.连接轴
- 8.制动轮
- 9.易爆塞
- 10.弹性块

Transmission VI:

- 1.Holding disc
- 2.Delay chamber
- 3.Outer wheel
- 4.Inner wheel
- 5.Explosion protection plug
- 6.Shell
- 7.Connection shaft
- 8.brake wheel
- 9.Fusible plug
- 10.Flexible element

规格型号 Specifacaton type	输入转速 Input speed n(r.p.m)	传递功率 范围 Ranger of power transmitted N (KW)	过载系数 Over load coeff Tg		效率 Effic iency η	最大输入孔 径及长度 Max.output bore diameter & Length d _{max} /l _{max}	最大输出孔 径及长度 Max.output bore diameter & Length d _{max} /l _{max}	充液量 (L) Volume of filling oil		外型尺寸 Dimensions (mm)							重量 Weight (kg)	
			启动 start	制动 brake				40% q _{min}	80% q _{max}	A	A ₁	D	B	D ₁	A _c	C		E
YOXDv II z400	1000	10-22	1.35-1.5	2.0-2.35	0.96	φ65/140	φ65/140	5.8	10.4	565	367	φ472	150	φ315	10	38	60	118
	1500	30-56																
YOXDv II z450	1000	17-35	1.35-1.5	2.0-2.35	0.96	φ75/140	φ75/140	8.3	15	619	421	φ530	150	φ315	10	38	50	134
	1500	55-110																
YOXDv II z500	1000	27-58	1.35-1.5	2.0-2.35	0.96	φ90/170	φ90/170	11.4	20.6	700	459	φ582 φ558	190	φ400	10	41	80	162
	1500	70-170																
YOXDv II z560	1000	45-100	1.35-1.5	2.0-2.35	0.96	φ100/210	φ100/210	14.6	26.4	765	520	φ640	190	φ400	10	45	85	213
	1500	140-315																
YOXDv II z600	1000	70-135	1.35-1.5	2.0-2.35	0.96	φ110/210	φ110/210	18.6	33.6	850	580	φ695	210	φ500	15	45	70	269
	1500	230-418																
YOXDv II z650	1000	100-205	1.35-1.5	2.0-2.35	0.96	φ120/210	φ120/210	26.6	48	876	606	φ760	210	φ500	15	45	60	396
	1500	300-560																
YOXDv II z750	1000	195-385	1.35-1.5	2.0-2.35	0.96	φ130/210	φ130/210	37.7	68	1001	686	φ860	250	φ630	15	50	90	499
	1500	550-885																
YOXDv II z875	750	168-325	1.35-1.5	2.0-2.35	0.96	φ140/250	φ140/250	62.1	112	1084	739	φ992	250	φ630	20	75	75	664
	1000	380-720																

说明: YOXDV II z型为加长后辅腔、输出端带制动轮, 使驱动单元结构紧凑, 延长工作机启动时间, 一般为22-30秒。此结构为带制动轮偶合器型式。此结构特别适用于启动加速度低、高带速、大惯量且要求带制动装置的胶带输送机。

Notes: YOXDV II z is a type with longer delay chamber with brake wheel in output side, making the structure closer and elong the startup time to 22-30s. This is the of brake wheel type, which is special suitable for startup of belt conveyor with low acceleration. High speed, large mass and with brake system.

一流产品 一流服务

First-class products First-class service



HENAN MODERN INDUSTRIAL CO LIMITED

ADD: NO.8 Linke ROAD, ZHENGZHOU, HENAN PROVINCE, CHINA Postcode: 450000

TEL: + 86-371-88881695 FAX: + 86-371-88881697 WEB: WWW.BRAKE.HK

限矩型液力耦合器的安全保护装置:

Operation Control Diagram Of Variable Speed Couplings:

一、易熔塞—耦合器过热喷液保护装置(图1)

原理功能

易熔塞芯部小孔中浇注了低熔点易熔合金，当耦合器过热温度超过合金的熔化温度后，易熔合金熔化，腔内工作液体在离心力作用下从易熔塞小孔中喷出，切断液力传动，从而达到过载保护的目的。

规格

油介质耦合器易熔塞规格表

耦合器型号	YOX150~280	YOX320~750	YOX875以上
易熔塞规格	M14×1.5	M18×1.5	M24×1.5

熔化温度

水介质耦合器— $115 \pm 5^\circ\text{C}$ 油介质耦合器— $130 \pm 5^\circ\text{C}$ 特殊场合— $140 \pm 5^\circ\text{C}$

注意事项

- 1、绝对不能用实心螺塞替代易熔塞，否则会引起耦合器过热升压爆炸。
- 2、过载时易熔塞喷液保护是正常发挥功能，不属于事故。
- 3、如频繁喷液应查找原因，消除耦合器功率不足或工作机超载。
- 4、喷液后应重新按规定充液，并使用新的易熔塞。
- 5、耦合器应安装护罩，避免喷液时污染环境。

二、易爆塞—耦合器超压保护装置(图2)

原理功能

水介质液力耦合器腔内充的清水温度升高后易汽化，使腔内压力升高，如不释放则可能引起耦合器爆炸。易爆塞中设置一块薄片金属，腔内压力升高到一定程度后，薄片金属被压向冲模刀刃似的座板，在压力和刃口双重作用下，薄片金属被破坏，于是汽体释放，保护耦合器不被破坏。

注意事项

- 1、绝对不可以用实心螺塞替代易爆塞。
- 2、易爆塞是国家强制检定配件，必须到指定部门购买。
- 3、易爆塞喷液时，热水超过 100°C ，应注意避免烫伤。

三、机械式温控开关—不喷液过热保护装置(图3、图4)

原理功能

耦合器上旋紧一个类似普通易熔塞的不喷液易熔塞。塞中有一个不通的小孔，孔中有一个被凝固后的易熔合金固定的销杆。当耦合器超温后，不喷液易熔塞中的易熔合金熔化，销杆被弹簧推出，拨动对面安装的行程开关，发出警报或关闭电机。

规格

目前机械式温控开关只有一个型号：YOXwk，其安装尺寸见图3。

注意事项

- 1、使用机械式温控开关也要安装喷液式普通易熔塞，通常温控开关中易熔合金的熔化温度比易熔塞中的易熔合金熔化温度低 10°C ，所以可以保证温控开关先反应，不喷液。
- 2、不喷液易熔塞在触发后，不能自动缩回，必须待耦合器降温后更换新的。
- 3、行程开关支架安装位置必须正确，需保证弹出的销杆能够拨动行程开关。耦合器上不喷液易熔塞的安装位置有径向和轴向两种，温控开关应相匹配。



图1耦合器易熔塞



图2易爆塞

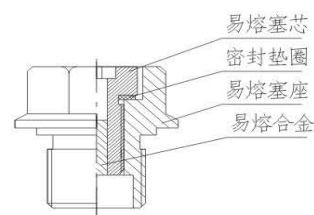

图4不喷液易熔塞

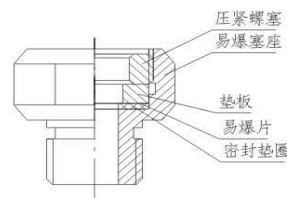

图3机械式温控开关

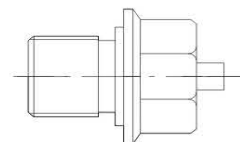

一流产品 一流服务
First-class products First-class service

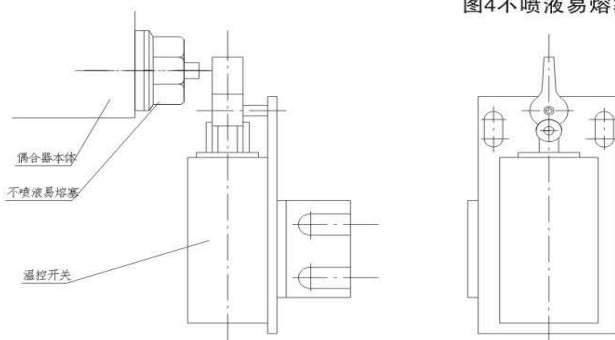

HENAN MODERN INDUSTRIAL, CO LIMITED

ADD: NO.8 Linke ROAD, ZHENGZHOU, HENAN PROVINCE, CHINA Postcode: 450000

TEL: + 86-371-88881695 FAX: + 86-371-88881697 WEB: WWW.BRAKE.HK

调速型液力耦合器

一、工作原理：

YOT系列调速型液力耦合器工作原理：使耦合器工作腔内充入一定的工作液(一般为32号透平油)，工作轮泵轮从电动机上获得机械能，并转化为液体动能，推动涡轮旋转，涡轮把液体动能转化为机械能，通过输出轴带动工作机工作，周而复始，实现了从原动机到工作机之间的能量传递。调速型液力耦合器之所以能够调速，是通过耦合器的导管改变导管开度，从而改变工作腔内工作液的充满度，在电机转速不变的情况下，实现对工作机的无级调速，改变输出功率的大小。因在传递能量变化时，产生转差率会使工作液发热，所以必须配备冷却器把工作液冷却，耦合器配有电动执行器，能接受执行控制信号并操作导管开度，亦可按用户要求配自动调速装置可以实现手动调速或自动控制。

二、优点：

- 1、用于需要调速的流体机械(如风机、泵类…)时，有显著的节电效果，节电率可达20~40%。
- 2、能使鼠笼式电动机空载起动，又能利用其尖峰力矩作起动力矩，提高其起动能力，缩短了电机起动时间，而使工作机滞后于电机缓慢起动。
- 3、用于多机驱动时，能协调功率平衡，减少电网冲击电流。
- 4、隔离扭振，减缓冲击，防止动力过载，保护电机与工作机，不会因过载而损坏。
- 5、易于实现对工作机的自动控制，操作简便。
- 6、提高工作机的使用寿命，减少噪音，改善了劳动环境。
- 7、投资少，简化电器设备，降低运行费用。
- 8、结构简单，可靠，无机械磨损，能在环境恶劣条件下工作，无需特殊维护，使用寿命长。

三、应用范围：

- 1、泵类：锅炉给水泵、循环泵、冷凝水泵、原油泵、输送泵、泥浆泵、灰渣泵、砂泵、柱塞泵。
- 2、风机类：转炉排烟风机、电炉除尘风机、高炉除尘风机、高炉鼓风机、化铁炉风机、烧结风机、锅炉鼓风机和引风机、均热炉鼓风机、引风机、送风机、预热循环风机、空调风机、吹粉风机、排粉风机、送风机、通风机、高压透平式压缩机、水泥转窑窑尾风机、水泥立窑罗茨风机等。
- 3、其他：破碎机、离心机、搅拌机、污水曝气器，胶带输送机。

I. Operation Principle

The YOT series variable speed fluid couplings are operating in the following principle: The rotating part consists of two bladed wheels—a Pump Wheel and a Turbine Wheel, the space between them is partially filled with a working fluid (#32 Turbine oil in general). The pump Wheel is driven by motor, the rotating wheel brings the fluid into rotation and thus convert input mechanical energy into fluid energy, back to mechanical energy. The quantity of fluid in the variable speed coupling can be varied during operation by means of a scoop tube and thus it is possible to adjust the power output level to meet the requirement at any time. The speed of the driven machine can be infinitely varied. A small portion of power is lost during the transmission which could warm up the working fluid, a heat exchanger is equipped to cool down the fluid. The speed is controlled by an electric actuator which is connected with the signals of load change. A tachometer can be installed for speed measurement upon customer's request. Depending on the application, the control of scoop tube can be either manual or automatic control

II. Advantages:

- (1) Good power saving at about 20–40% when used with fans, pumps etc.
- (2) Allow the motor to start at virtually no load, and then accelerate the driven machine at its maximum torque.
- (3) Synchronize multi-motor drive.
- (4) Dampens shocks and vibrations, minimize excessive torque on motor
- (5) Allow remote control on speed of drive. Step less speed adjustment.
- (6) Reduce noise, improve environment and prolong service life of machine.
- (7) Low investment, high reliability.
- (8) Simple design, no mechanical wear, reliable even under most adverse environment

III. Applications:

- (1) Pumps: boiler feed pumps, circulation pumps, cooling and condensation pumps, crude oil pumps, pipeline pumps, ash pumps, piston pumps
- (2) Fans: ventilation fans, induce draft fans, forced draft fans, blowers, compressors etc. Used in steel plants, power plants and cement plants.
- (3) Others: Centrifugal machines, mixers, belt conveyors etc.



一流产品 一流服务

First-class products First-class service



HENAN MODERN INDUSTRIAL, CO LIMITED

ADD: NO.8 Linke ROAD, ZHENGZHOU, HENAN PROVINCE. CHINA Postcode: 450000

TEL: + 86-371-88881695 FAX: + 86-371-88881697 WEB: WWW.BRAKE.HK

YOTcs箱体式调速型液力耦合器： YOTcs Variable Speed Couplings:

1、结构特点：

- 1.1 适用范围广，可在不同输入转速及功率下运行。
- 1.2 以箱体支承旋转组件，刚性大，抗振性好，维护保养方便。

2. 结构原理简图：(见右图)

- | | | |
|----------|----------|---------|
| P. 泵轮 | T. 涡轮 | S. 导管腔 |
| 1. 输入轴 | 2. 输出轴 | 3. 箱体 |
| 4. 导管壳体 | 5. 导管 | 6. 油泵 |
| 7. 输入轴承 | 8. 埋入轴承 | 9. 泵轮轴承 |
| 10. 输出轴承 | 11. 吸口滤网 | 12. 冷却器 |

1. Structure characteristic

- 1.1. Operation under different input speed & power is possible
- 1.2. Simple in maintenance with good rigidity & anti-vibration of rotation parts

2. Figure:

- | | | |
|--------------------|------------------|--------------------------|
| P. Pump wheel | T. Turbo wheel | S. Scoop chamber |
| 1. Input shaft | 2. Output shaft | 3. Housing |
| 4. Scoop case | 5. Scoop tube | 6. Oil pump |
| 7. Input bearing | 8. Inset bearing | 9. Bearing of pump wheel |
| 10. Output bearing | 11. Filter | 12. Cooler |

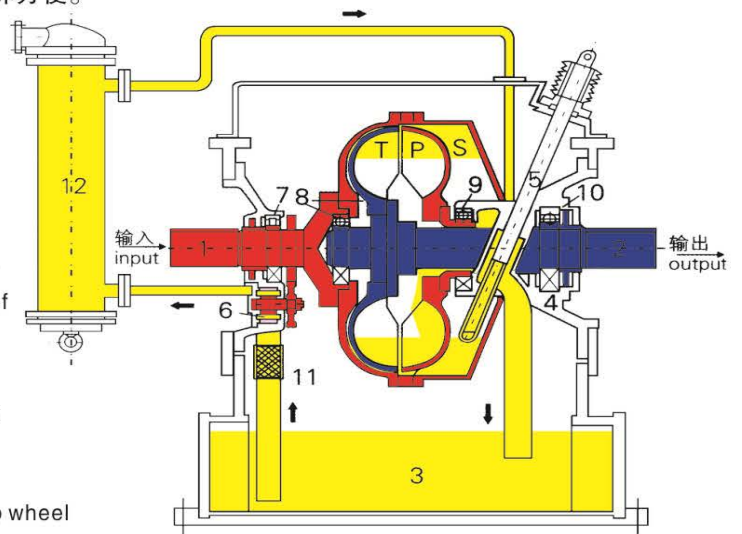

3. 外形尺寸图：

Figure of external dimension

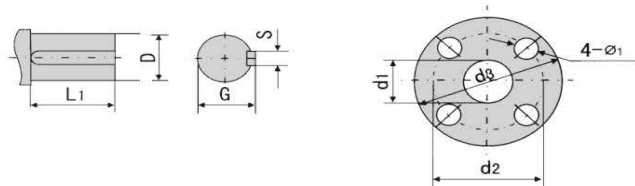
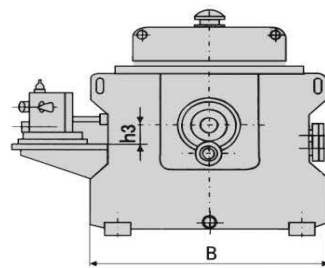
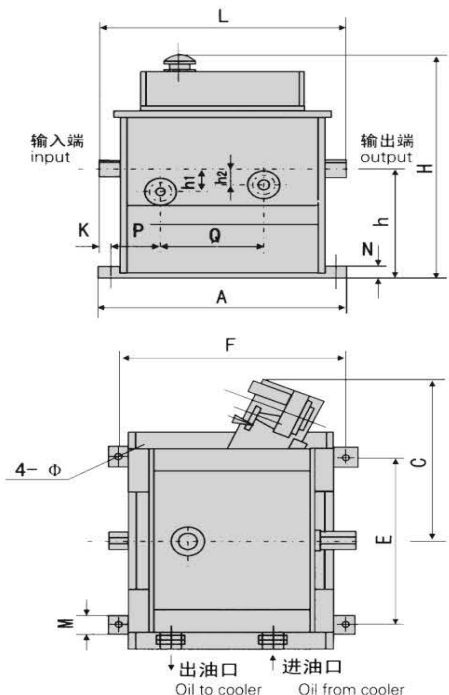

注：输入、输出端分别用一对弹性套柱销联轴器(GB4323—84)与电动机、工作机联接，有关联接尺寸由用户提供，输出端联轴器上加工测速齿圈(60齿)，或用户自行设计制造。

Note: There is a pair of connecting couplings both and output aides (GB4323—84). Which connected with motor and working machine. Dimensions are provide by users. Output side is machined with gears(60), or designed by users.

一流产品 一流服务

First-class products First-class service



HENAN MODERN INDUSTRIAL, CO LIMITED

ADD: NO.8 Linke ROAD, ZHENGZHOU, HENAN PROVINCE. CHINA Postcode: 450000

TEL: + 86-371-88881695 FAX: + 86-371-88881697 WEB: WWW.BRAKE.HK

YOTcp中心剖分式调速型液力耦合器: YOTcp Variable Speed Couplings:

1、结构特点:

- 1.1 适用于中、高转速及中、大功率工况的大规格产品,价格比YOTcs系列产品稍高。
- 1.2 以旋转件轴线把箱体分成两部分,结构紧凑,刚性好,可靠性高。拆下箱盖,无需移动电机、工作机便可拆出旋转件,维护检修方便。

2. 结构原理简图: (见右图)

- | | | |
|----------|----------|---------|
| P. 泵轮 | T. 涡轮 | S. 导管腔 |
| 1. 输入轴 | 2. 输出轴 | 3. 箱体 |
| 4. 导管壳体 | 5. 导管 | 6. 油泵 |
| 7. 输入轴承 | 8. 埋入轴承 | 9. 泵轮轴承 |
| 10. 输出轴承 | 11. 吸口滤网 | 12. 冷却器 |

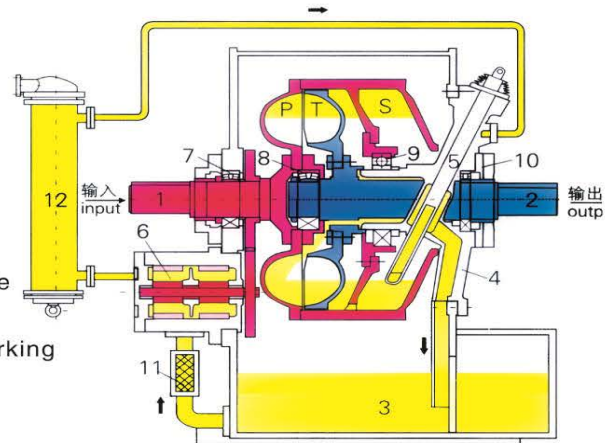

1. Structure characteristic

- 1.1 Suitable for high speed & large power. It's price is about a little higher than YOTcs's.
- 1.2 Rotation parts can be removed without moving motor and working machine. Easy maintenance.

2. Figure:

- | | | |
|--------------------|------------------|--------------------------|
| P. Pump wheel | T. Turbo wheel | S. Scoop chamber |
| 1. Input shaft | 2. Output shaft | 3. Housing |
| 4. Scoop case | 5. Scoop tube | 6. Oil pump |
| 7. Input bearing | 8. Inset bearing | 9. Bearing of pump wheel |
| 10. Output bearing | 11. Filter | 12. Cooler |

3. 外形尺寸图:

Figure of external dimension

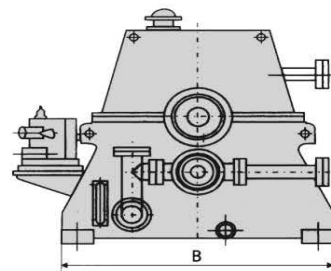
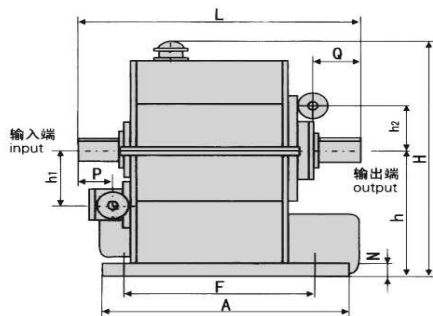

输入.输出端轴伸尺寸
Dimension of shaft ends

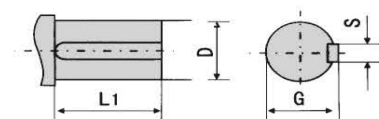
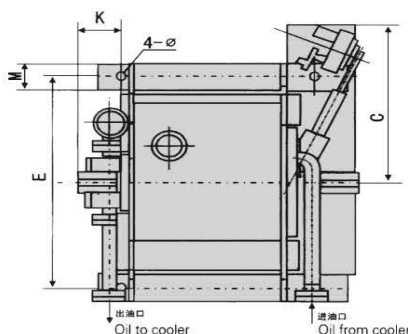

注: 输入、输出端分别用一对弹性套柱销联轴器(GB4323—84)与电动机、工作机联接,有关联接尺寸由用户提供,输出端联轴器上加测速齿圈(60齿),或用户自行设计制造。

Note: There is a pair of connecting couplings both and output aides (GB4323-84). Which connected with motor and working machine. Dimensions are provide by users. Output side is machined with gears(60), or designed by users.



一流产品 一流服务

First-class products First-class service



HENAN MODERN INDUSTRIAL, CO LIMITED

ADD: NO.8 Linke ROAD, ZHENGZHOU, HENAN PROVINCE. CHINA Postcode: 450000

TEL: + 86-371-88881695 FAX: + 86-371-88881697 WEB: WWW.BRAKE.HK

YOTGCD型（箱体对开式调速型液力耦合器）：

YOTGCD Type Structural Drawing and Main Technical Date:

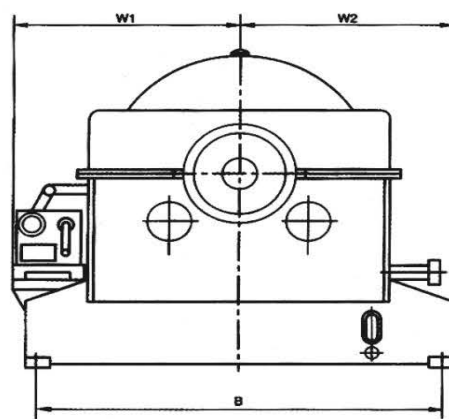
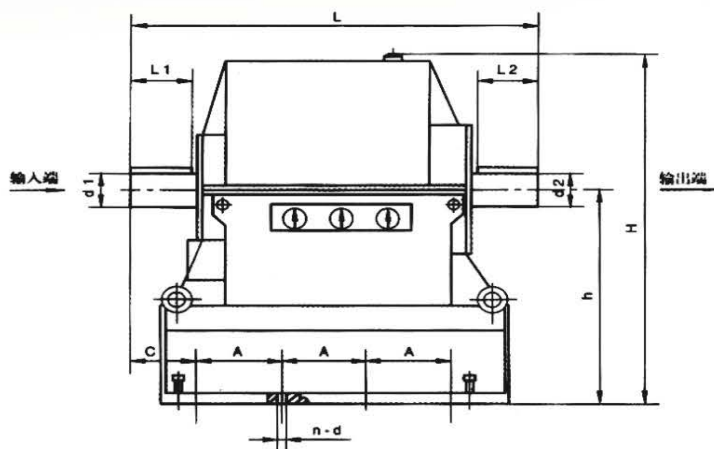

规格型号 Specification type	输入转速 Input speed r/min (r/min)	传递功率 Power transmitted (kw)	L	h	A	B	C	d1 d2	L1 L2	H	W1	W2	N-d
YOTGCD560	1500 1000	115-340 35-100	930	700	3-225	1140	93.5	φ 75	140	1184	900	600	8-φ 22
YOTGCD650	1500 1000	250-730 75-215	1100	700	3-225	1140	113.5	φ 85	150	1505	900	600	8-φ 22
YOTGCD750	1500 1000	510-1480 150-440	1200	750	4-200	1450	152.5	φ 100	150	1555	950	750	10-φ 22
YOTGCD800	1500 1000	740-2080 230-610	1300	750	4-200	1450	202.5	φ 120	210	1555	1050	755	10-φ 22
YOTGCD875	1000 750	365-960 150-400	1400	850	3-320	1500	220	φ 125	250	1500	1050	800	8-φ 28
YOTGCD1000	1000 750	640-1860 285-750	1500	900	4-240	1650	220	φ 135	250	1595	1150	855	10-φ 28
YOTGCD1050	1000 750	815-2300 360-955	1650	1150	4-320	1750	185	φ 150	250	1938	1200	925	10-φ 35
YOTGCD1150	750 600	715-1865 360-955	1650	1150	4-320	1750	185	φ 150	250	1938	1200	925	10-φ 35

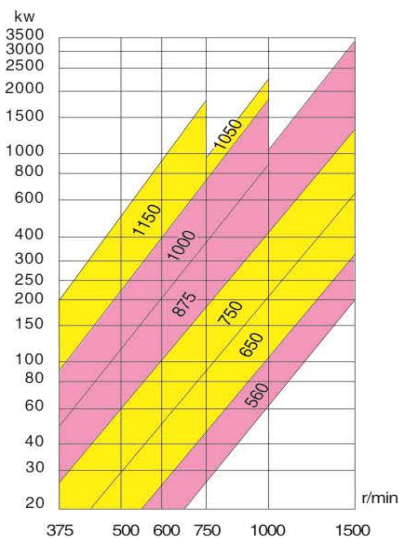

- 说明:
- 1、此类液力耦合器的额定转差率为1.5~3%。用于 $M \propto n^2$ 的离心式机械时，其调速范围为1~1/5；用于 $M=C$ 的恒扭矩机械时，其调速范围为1~1/3。
 - 2、d1、d2、L1、L2可按用户提供尺寸加工。
 - 3、户外型的标记为在型号后加W。
 - 4、井下用防爆型的标记为在型号后加B。

一流产品 一流服务
First-class products First-class service



HENAN MODERN INDUSTRIAL, CO LIMITED

ADD: NO.8 Linke ROAD, ZHENGZHOU, HENAN PROVINCE. CHINA Postcode: 450000

TEL: + 86-371-88881695 FAX: + 86-371-88881697 WEB: WWW.BRAKE.HK

订货时应提出和确定的项目： Items Should Be Specified On Placing Orders:

1. 订货时要提供及注明的项目：(Items should be specified:)

项目(Item)	产品类型(Size)	YOTcs	YOTcp	YOTGcd					
转向(Direction)		★	★	★					
电动机执行器类型(Electric Actuator)		★	★	★					
电动机执行器安装位置 Mounting Position Of Actuator		★	▲	★					
电机和工作机轴伸尺寸 Bore Dimension Between Motor & Driven Machine		▲	▲	▲					
电机和工作机法兰尺寸 Flange Dimension Between Motor & Driven Machine									

备注：1、有★标记者为必须注明。2、有▲标记者为合同有要求时必须提供。3、转向为站在电机端看偶合器输入端的旋转方向。
4、电动机执行器安装位置是在偶合器安装位置受到限制或特殊环境下电动机执行器位置必须确定，如无要求，则按偶合器外形尺寸图。

Note: 1. Item with ★ must be specified. 2. Item with ▲ must be supplied when specified in Contract. 3. "Direction" means the rotation direction on the input of coupling from motor side. 4. "Mounting Position of Actuator" means the special position of actuator when limited by couplings or special conditions. If not specified, just as "External Dimension Figure of Couplings".

2. 配套件供货项目：(Items of kit supply)

项目	产品类型	YOTcs	YOTcp	YOTGcd					
电动机执行器 Electric Actuator		★	★	★					
电动机操作器 Electric Operator		★	★	▲					
伺服放大器 servo amplifier		▲	▲	▲					
电接点温度计 Electric Contact Thermometer		★	★	★					
温度控制器 Temperature Control		▲	▲	▲					
铂热电阻 Platinum Resistance		▲	▲	▲					
温度变送器 Temperature Transmitter		▲	▲	▲					
电接点压力表 Electric Contact Gauge Monometer		★	★	★					
压力控制器 Pressure Control		▲	▲	▲					
压力变送器 Pressure Transformer Transmitter		▲	▲	▲					
测速装置 Speed Inspection Device		▲	▲	▲					
电加热装置 Electric Heater		▲	▲	▲					
液位控制器 Level Control		▲	▲	▲					
冷却器 Cooler		▲	▲	▲					
联轴器 Shaft Coupling		▲	▲	▲					
联轴器保护罩 Cover		▲	▲	▲					
偶合器底座或台板 Pedestal or Plate of Couplings		▲	▲	▲					
接线端子箱 Thermal Box		▲	▲	▲					
现场仪表柜 Instrument Control Cabinet on site		▲	▲	▲					
控制室仪表柜 Instrument Control cabinet Room		▲	▲	▲					
自动控制装置 Servomechanism		▲	▲	▲					

备注：1、有★标记者产品上已配套。
2、有▲标记者为合同有要求时配套提供。



一流产品 一流服务
First-class products First-class service



HENAN MODERN INDUSTRIAL, CO LIMITED

ADD: NO.8Linke ROAD, ZHENGZHOU, HENAN PROVINCE. CHINA Postcode: 450000
TEL: + 86-371-88881695 FAX: + 86-371-88881697 WEB: WWW.BRAKE.HK

调速型液力耦合器操作控制原理图: Operation Control Diagram Of Variable Speed Couplings:

1、导管位置操作控制原理(开环控制系统) Position Control Circuit

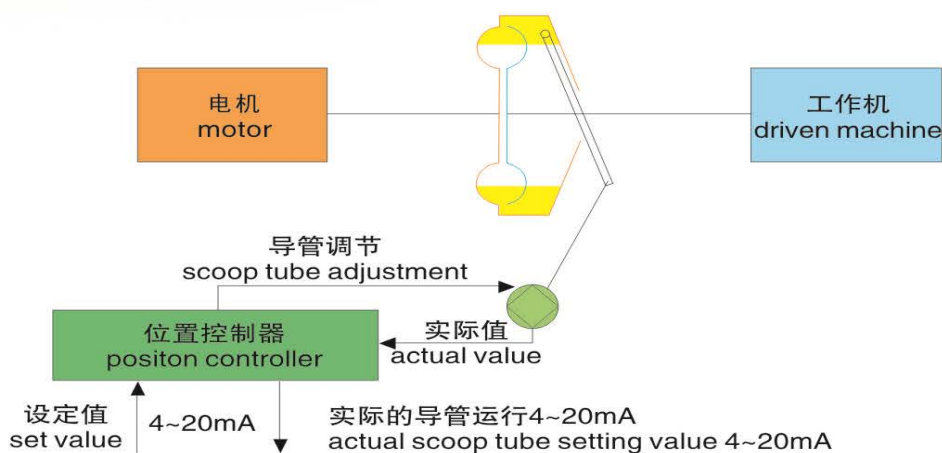

2、耦合器过程操作控制原理(闭环控制系统) Process Control Circuit

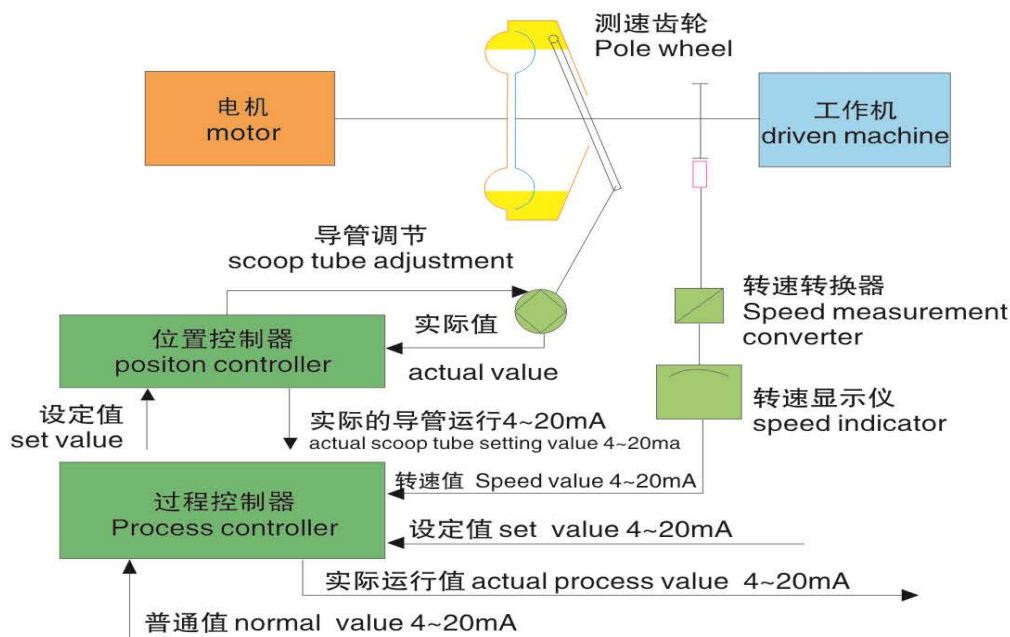



一流产品 一流服务

First-class products First-class service



HENAN MODERN INDUSTRIAL, CO LIMITED

ADD: NO.8 Linke ROAD, ZHENGZHOU, HENAN PROVINCE. CHINA Postcode: 450000

TEL: + 86-371-88881695 FAX: + 86-371-88881697 WEB: WWW.BRAKE.HK

ML型梅花形弹性联轴器:
ML type coupling with elastic spider:

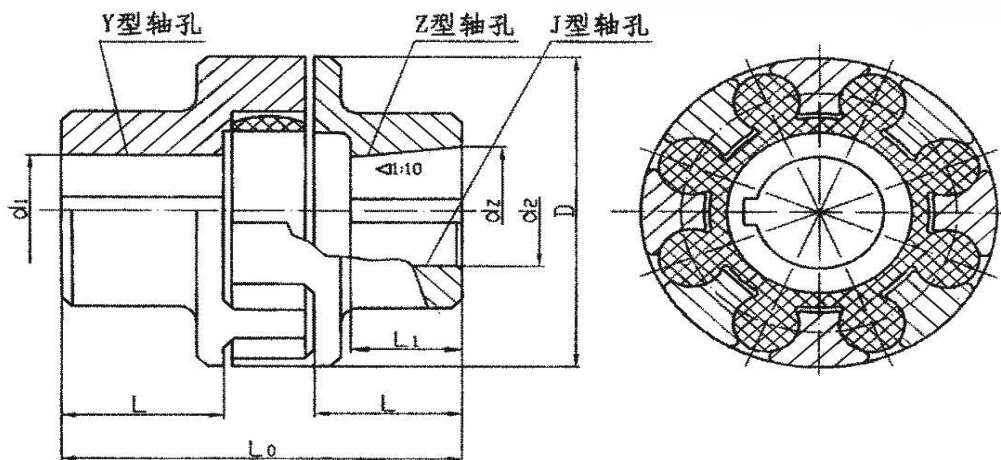

mm

型号 Specification type	公称转矩 Nominal Torque T _n N · m	轴孔直径 Diameter of Axis Hole d ₁ , d ₂ , d _z	轴孔长度 Length of Axis Hole	L ₀ max	D	S	弹性 件 型号	质量 Weight Kg
			Y, J, Z L, L ₁					
ML1	16-45	12-24	27-52	80-120	50	2	MT1	0.66
ML2	63-200	20-32	38-82	127-187	70	2.5	MT2	1.55
ML3	90-280	22-38	38-82	128-188	85	3	MT3	2.5
ML4	140-400	25-42	44-112	151-257	105	3.5	MT4	4.3
ML5	250-710	30-48	60-112	197-257	125	4	MT5	6.2
ML6	400-1120	35-55	60-112	203-263	145	4.5	MT6	8.6
ML7	710-2240	45-65	84-142	265-325	170	5.5	MT7	14.0
ML8	1120-3550	50-75	84-142	272-332	200	6.5	MT8	25.7
ML9	1800-5600	60-95	107-172	334-394	230	7.5	MT9	41.0
ML10	2800-9000	70-110	107-212	344-484	260	7.5	MT10	59.0
ML11	4000-12500	80-120	132-212	411-191	300	8.5	MT11	87.0
ML12	7100-20000	90-130	132-252	417-577	360	9	MT12	140
ML13	8000-25000	100-140	167-250	497-577	400	9	MT13	160



一流产品 一流服务

First-class products First-class service



HENAN MODERN INDUSTRIAL, CO LIMITED

ADD: NO.8Linke ROAD, ZHENGZHOU, HENAN PROVINCE. CHINA Postcode: 450000

TEL: + 86-371-88881695 FAX: + 86-371-88881697 WEB: WWW.BRAKE.HK 金田液力 品质源于专注

MLL-I型带制动轮梅花形弹性联轴器：
MLL-I type coupling with elastic spider with brake wheel:

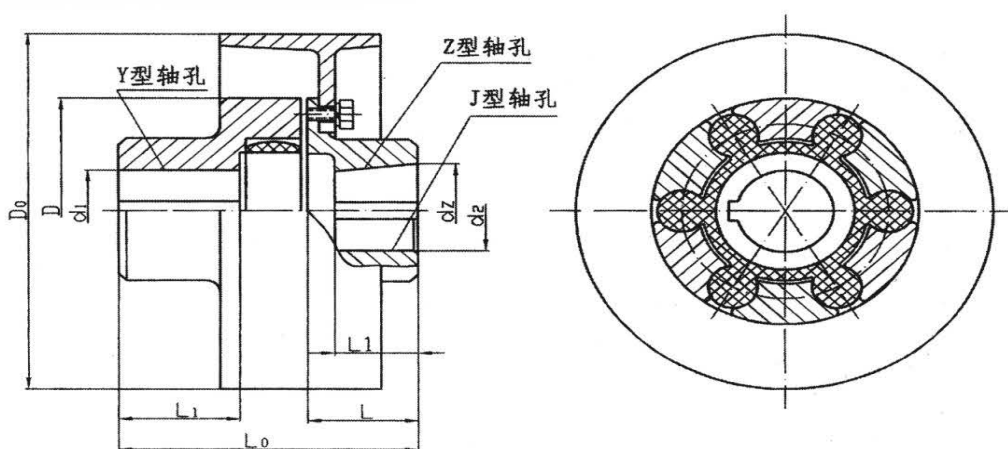

mm

型号 Specifacaton type	公称转矩 Nominal Torque T _n N·m	轴孔直径 Diameter of Axis Hole d ₁ , d ₂ , d _z	轴孔长度 Length of Axis Hole		L ₀	D ₀	B	D	弹性 件 型号	质量 Weight Kg
			Y	J, Z						
			L, L ₁							
MLL4-I-160	140-400	25-42	62-112	44-84	151-251	160	70	105	MT4	8.5
MLL4-I-200						200	80			9.5
MLL5-I-200	250-800	30-48	82-112	60-84	197-257	200	85	125	MT5	13.8
MLL6-I-200	400-1120	35-55	82-112	60-84	203-263	200	85	145	MT6	16.7
MLL6-I-250						250	105			21.7
MLL7-I-250	710-2240	45-65	112-142	84-107	265-325	250	105	170	MT7	26.3
MLL7-I-315						315	135			34.7
MLL8-I-315	1120-3550	50-75	112-142	84-107	272-332	315	135	200	MT8	47.3
MLL8-I-400						400	170			61.3
MLL9-I-400	1800-5600	60-95	142-172	107-132	334-394	400	170	230	MT9	84.0
MLL9-I-500						500	210			108
MLL10-I-500	2800-9000	70-110	142-212	107-167	344-484	500	210	260	MT10	132
MLL11-I-630	4000-12500	80-120	172-212	132-167	411-491	630	265	300	MT11	197
MLL12-I-710	7100-20000	90-130	172-252	132-202	417-577	710	300	360	MT12	212



一流产品 一流服务

First-class products First-class service



HENAN MODERN INDUSTRIAL, CO LIMITED

ADD: NO.8 Linke ROAD, ZHENGZHOU, HENAN PROVINCE. CHINA Postcode: 450000

TEL: + 86-371-88881695 FAX: + 86-371-88881697 WEB: WWW.BRAKE.HK

HL 型、HLL带制动轮型弹性柱销联轴器：

HL type and HLL elastic pin coupling with brake wheel:

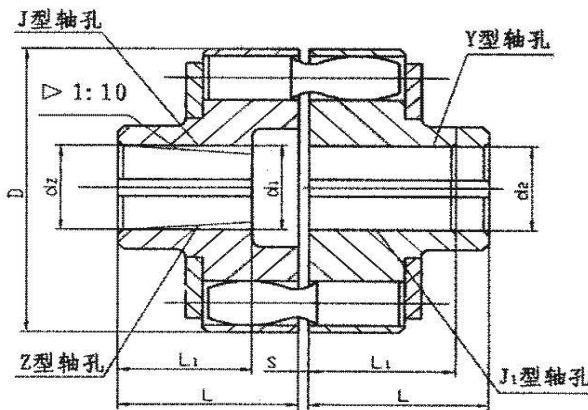

HL型

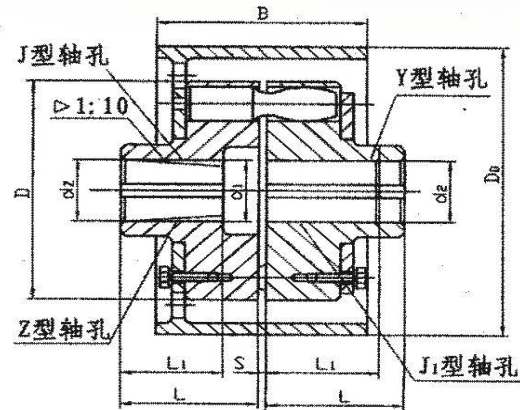

HLL型

型号 Specification type		公称转矩 Nominal Torque T _n N · m	轴孔直径 Diameter of Axis Hole d _z , d ₁ , d ₂	轴孔长度L、L ₁ Length of Axis Hole Y, J, J ₁ , Z		D	S	D ₀	B	质量 Weight Kg	
HL	HLL			HL	HLL					HL	HLL
HL1	—	160	12-24	27-52	—	90	2.5	—	—	2	—
HL2	HLL1	315	20-35	38-82	38-82	120	2.5	200	85	5	11
HL3	HLL2/HLL3	630	30-48	60-112	60-112	160	2.5	200/315	85/132	8	14/25
HL4	HLL4/HLL5	1250	40-63	84-142	84-142	195	3	315/400	132/168	22	40/59
HL5	HLL6/HLL7	2000	50-75	107-142	84-142	220	3	400/500	168/210	30	69/91
HL6	HLL8/HLL9	3150	60-85	107-172	107-172	280	4	400/500	168/210	53	88/113
HL7	HLL10/HLL11	6300	70-110	107-212	107-212	320	4	500/630	210/265	98	156/189
HL8	HLL12	10000	80-125	167-212	132-212	360	5	630	265	119	326
HL9	HLL13	16000	100-140	167-252	167-252	410	5	710	298	197	337
HL10	HLL14/HLL15	25000	110-180	167-302	167-302	480	6	710/800	298/335	322	458/504
HL11	—	31500	130-220	202-352	—	540	6	—	—	520	—
HL12	—	63000	160-260	242-410	—	630	7	—	—	714	—
HL13	—	100000	190-300	282-470	—	710	8	—	—	1057	—
HL14	—	160000	240-340	330-550	—	800	8	—	—	1956	—



一流产品 一流服务

First-class products First-class service



HENAN MODERN INDUSTRIAL, CO LIMITED

ADD: NO.8 Linke ROAD, ZHENGZHOU, HENAN PROVINCE. CHINA Postcode: 450000

TEL: + 86-371-88881695 FAX: + 86-371-88881697 WEB: WWW.BRAKE.HK

TL型、TLL带制动轮型弹性套柱销联轴器：

TL type and TLL HLL pin coupling with brake wheel and elastic sleeve:

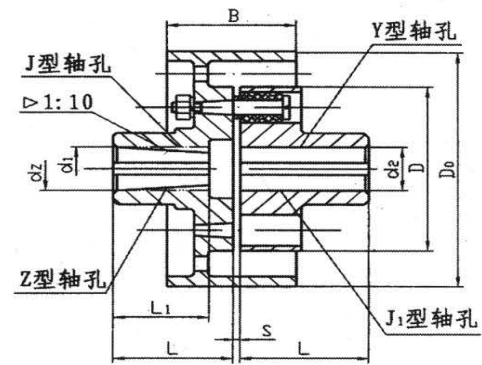
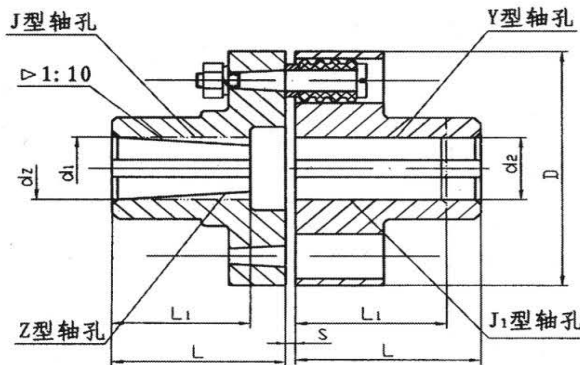

mm

型号 Specifacaton type		公称转矩 Nominal Torque T _n N·m	轴孔直径 Diameter of Axis Hole d ₁ , d ₂ , d _z	轴孔长度 Length of Axis Hole Y, J, J ₁ , Z		D	S	A	D ₀	B	质量 Weight Kg	
TL	TLL			L	L ₁						TL	TLL
TL1	—	6.3	9-14	14-32	71	3	18	—	—	1.16	—	
TL2	—	16	12-19	20-42	80	3	18	—	—	1.64	—	
TL3	—	31.5	16-22	30-52	95	4	35	—	—	2.2	—	
TL4	—	63	20-28	38-62	106	4	35	—	—	3.2	—	
TL5	TLL1	125	25-35	44-82	130	5	45	200	85	8.36	8.3	
TL6	TLL2	250	32-42	60-112	160	5	45	250	105	10.36	15.3	
TL7	TLL3	500	40-48	84-112	190	5	45	315	132	15.7	30.0	
TL8	TLL4	710	45-63	84-142	224	6	65	315	132	25.4	39.6	
TL9	TLL5	1000	50-71	84-142	250	6	65	315	168	31	47.0	
TL10	TLL6	2000	60-95	107-172	315	8	80	400	168	65.9	92.6	
TL11	TLL7	4000	80-120	132-212	400	10	100	500	210	122.6	172.3	
TL12	TLL8	8000	100-130	167-252	475	12	130	500/630	210/265	218.4	304.3	
TL13	TLL9	16000	120-170	167-302	600	14	180	710	298	425.8	576.8	



一流产品 一流服务
First-class products First-class service



HENAN MODERN INDUSTRIAL, CO LIMITED

ADD: NO.8 Linke ROAD, ZHENGZHOU, HENAN PROVINCE, CHINA Postcode: 450000

TEL: + 86-371-88881695 FAX: + 86-371-88881697 WEB: WWW.BRAKE.HK

ZL型弹性柱销齿式联轴器：
ZL type gear coupling with elastic pins:

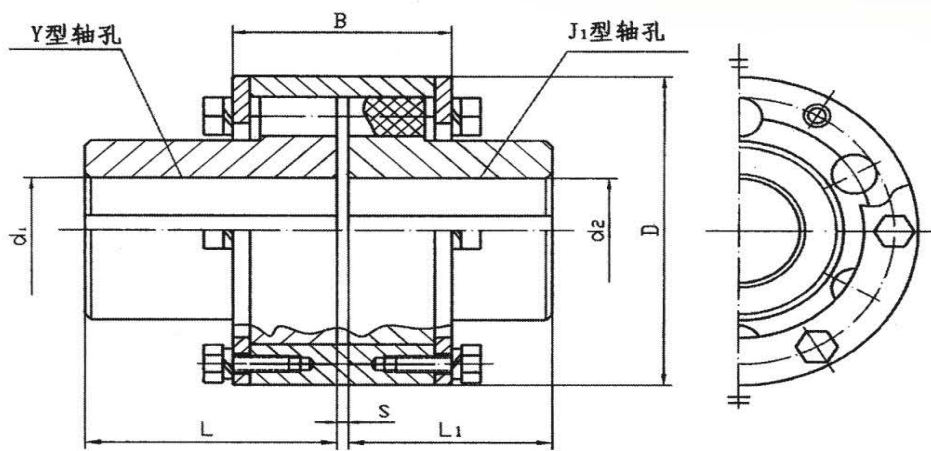

mm

型号 Specification type	公称转矩 Nominal Torque T _n N · m	轴孔直径 Diameter of Axis Hole d ₁ , d ₂ , d ₃	轴孔长度 Length of Axis Hole		D	B	S	质量 Weight Kg
			Y, J ₁ L	J ₁ L ₁				
ZL1	100	12-24	27-52		76	42	2.5	0.86
ZL2	250	16-32	30-82		92	50	2.5	3.23
ZL3	630	25-42	44-112		118	69	3	6.57
ZL4	1600	40-60	84-142		158	89	4	14.8
ZL5	4000	50-80	84-172		192	89	4	24.8
ZL6	6300	60-95	107-172		230	111	5	42.5
ZL7	10000	70-110	107-212		260	113	5	66.3
ZL8	16000	80-130	132-252		300	136	6	107.3
ZL9	25000	90-150	132-252		335	149	7	140.9
ZL10	31500	100-170	167-302		355	151	8	180.9
ZL11	40000	110-180	167-302		380	170	8	219.3
ZL12	63000	130-200	202-352		445	183	8	371.4
ZL13	100000	150-240	202-410		515	218	8	470.0
ZL14	125000	170-260	242-410		560	218	8	708.0
ZL15	160000	190-300	282-470		590	238	10	768.0
ZL16	250000	220-340	282-550		695	262	10	1169
ZL17	315000	240-380	330-550		768	282	10	1664
ZL18	400000	250-420	330-650		860	300	13	2193
ZL19	630000	280-450	380-650		970	320	14	2901
ZL20	1000000	320-500	380-650		1156	351	15	4251
ZL21	1600000	380-630	450-800		1440	355	18	7514
ZL22	2000000	420-750	540-900		1520	396	19	10148
ZL23	2500000	480-850	540-1000		1638	430	20	13026

一流产品 一流服务
First-class products First-class service



HENAN MODERN INDUSTRIAL, CO LIMITED

ADD: NO.8 Linke ROAD, ZHENGZHOU, HENAN PROVINCE. CHINA Postcode: 450000

TEL: + 86-371-88881695 FAX: + 86-371-88881697 WEB: WWW.BRAKE.HK

厂区图片
Factory Picture



产品应用现场 Product Application Site:





PRODUCT DISPLAY
 HENAN MODERN INDUSTRIAL CO.,LIMITED

产品展示 / **HVIC**



MODERN INDUSTRIAL



Overload Limiter For Single-beam Crane



Overload Limiter for Double-beam Crane



Crane Electronic Scales



Electro Hydarulic Disc Brake



YPA3 Hydraulic Power Unit



Electro Hydraulic Emergency Brake



FCL COUPLING



HRC Coupling&Rubber Insert



NM COUPLING



Motorized Drum Pulley



Cycloidal Reducer



YOX Series Fluid Coupling

HMIC - GREAT VALUE FOR YOU. APPLICATION FIELD

HENAN MODERN INDUSTRIAL CO., LIMITED

应用领域 / 



USING CASE:

- CRANE
- CEMENT
- MINING
- STEEL MILL
- POWER PLANT

EVERYTHING ABOUT CRANE, CEMENT, MINING, STEEL MILL, ENERGY PLANT.



HENAN MODERN
INDUSTRIAL CO., LIMITED

HMIC CHINA LOCATIONS



Manufacturing: ◆

Direct Sales: ■

Partners: ●

**Manufacturing:
MAIN INDUSTRY**

Crane Industry
Cement Industry
Metallurgy Industry
Mining Industry

**Main Market:
International**

Sidney, Australia
Sao Paulo, Brazil
India, Russia, Turkey, China
Cuernavaca, Mexico
Manchester, UK

Direct Sales:

China MainLand
Moscow, Russia
Hanoi, Vietnam
Ho Chi Minh, Vietnam
Kenya, Istanbul, Turkey
Singapore India

Worldwide Partners

Australia
Austria
Canada
China-Hong Kong
China-TaiWan
Romania
Columbia
Denmark
Turkey
Netherlands

Egypt
Finland
France
Hungary
Indonesia
Israel
Italy
Brazil
Korea
Vietnam

New Zealand
Phillipines
Poland
Singapore
South Africa
Spain
Sweden
Switzerland
Thailand

Shipping Address: HuaYuan Road, ZhengZhou City, HeNan Province, China,
Mailing Address: P.O 450000, ZhengZhou City, HeNan Province, China
Tel: 86-371-8888.1695 • **Fax:** 371-8888-1697 • **Mob:** 86-158-3717-1618
Internet Address: www.BRAKE.HK www.phoebusbelt.com • **Email:** sales@Brake.HK